

第3章. 上水道編

第5節 業務統計

1 配水分析

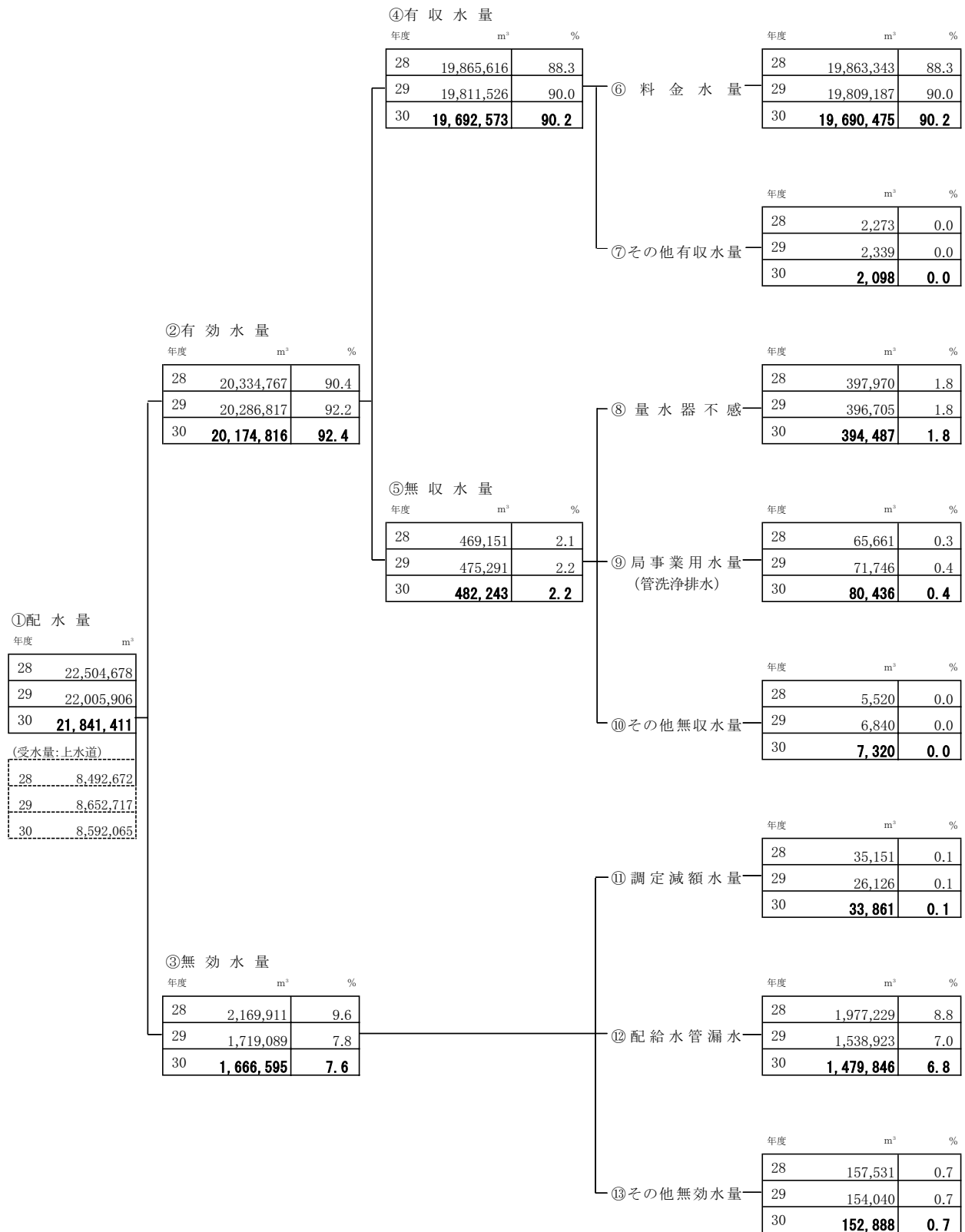

2 加入金の推移と変遷

(1) 加入金の推移

上段：上・簡水合算
中段：上水道事業
下段：簡易水道事業

単位(件数):件
単位(金額):千円

口径 区分	年度		26		27		28		29		30	
	件数	金額	構成比 (%)	構成比 (%)	構成比 (%)	構成比 (%)	構成比 (%)	構成比 (%)	構成比 (%)	構成比 (%)		
13mm	621	41.3	859	58.4	779	47.96	661	44.30	542	40.15		
	617	41.2	858	58.4	50,479	34.75	42,736	29.40	35,122	27.95		
	4	80.0	1	50.0								
40,221	29.1	55,663	41.7									
20mm	721	48.0	526	35.8	688	42.36	670	44.91	698	51.70		
	721	48.2	525	35.7	66,874	46.04	65,124	44.80	66,874	53.22		
	0	0.0	1	50.0								
70,081	50.8	51,127	38.3									
25mm	27	1.8	34	2.3	40	2.46	49	3.28	45	3.33		
	27	1.8	34	2.3	7,776	5.35	9,526	6.55	8,748	6.96		
	0	0.0	0	0.0								
5,249	3.8	6,610	5.0									
40mm	4	0.3	9	0.6	2	0.12	8	0.54	4	0.30		
	4	0.3	9	0.6	1,296	0.89	5,184	3.57	2,009	1.60		
	0	0.0	0	0.0								
2,592	1.9	5,832	4.4									
50mm	1	0.1	3	0.2	0	0.00	1	0.07	2	0.15		
	1	0.1	3	0.2	0	0.00	1,231	0.85	2,462	1.96		
	0	0.0	0	0.0								
1,231	0.9	3,694	2.8									
75mm	1	0.1	0	0.0	0	0.00	1	0.07	0	0.00		
	0	0.0	0	0.0	0	0.00	3,110	2.14	0	0.00		
	1	20.0	0	0.0								
3,110	2.3	0	0.0									
100mm	0	0.0	0	0.0	0	0.00	0	0.00	0	0.00		
	0	0.0	0	0.0	0	0.00	0	0.00	0	0.00		
	0	0.0	0	0.0								
0	0.0	0	0.0									
小計	1,375	91.5	1,431	97.3	1,509	92.91	1,390	93.16	1,291	95.63		
	1,370	91.5	1,429	97.3	126,425	87.03	126,911	87.30	115,214	91.70		
	5	100.0	2	100.0								
122,485	88.7	122,926	92.1									
口径変更	127	8.5	40	2.7	115	7.08	102	6.84	59	4.37		
	127	8.5	40	2.7	18,824	12.96	18,468	12.70	10,433	8.30		
	0	0.0	0	0.0								
15,552	11.3	10,498	7.9									
合計	1,502	100.0	1,471	100.0	1,624	100.00	1,492	100.00	1,350	100.00		
	1,497	100.0	1,469	100.0	145,249	100.00	145,379	100.00	125,647	100.00		
	5	100.0	2	100.0								
138,037	100.0	133,423	100.0									
合計	134,667	100.0	133,261	100.0	145,249	100.00	145,379	100.00	125,647	100.00		
	3,370	100.0	162	100.0								

(2) 加入金の変遷

【水道事業】

旧佐賀市

(単位:千円 消費税抜)

口径 改定日	13mm	20mm	25mm	40mm	50mm	75mm	100mm	150mm	200mm以上
昭和55. 4. 1	30	40	70	220	390	900	1,900	150mm 以上は管 理者が別 に定める	
59. 4. 1	40	60	120	400	800	2,000	3,800		
63. 4. 1	50	75	150	500	950	2,400	4,500		
平成 4.12. 1	60	90	180	600	1,140	2,880	5,400		
9.10. 1	60	90	180	600	1,140	2,880	5,400	10,800	管理者が別に定める

旧大和町

(単位:千円 消費税抜)

口径 改定日	13mm	20mm	25mm	40mm	50mm	75mm	100mm	150mm
平成 4.4.1	120	168	287	777	1,360	3,059	5,437	町長が定める

新佐賀市

(単位:千円 消費税抜)

口径 改定日	13mm	20mm	25mm	40mm	50mm	75mm	100mm	150mm	200mm以上
平成 18.4.1	60	90	180	600	1,140	2,880	5,400	10,800	管理者が別に定める

【簡易水道事業】

大和簡易水道・大和飲料水供給施設

(単位:千円 消費税抜)

口径 改定日	13mm	20mm	25mm	40mm	50mm	75mm	100mm	150mm	200mm以上
平成 10.12.24	120	168	287	777	1,360	3,059	5,437	町長が定 める	-
平成 18.4.1	佐賀市水道事業の給水条例の規定の例による								

富士南部簡易水道

(単位:千円 消費税抜)

口径 改定日	13mm	20mm	25mm	40mm	50mm	75mm	100mm	150mm	200mm以上
平成 16.4.1	120	168	-	-	-	-	-	-	-
平成 18.4.1	佐賀市水道事業の給水条例の規定の例による								

【水道事業】

現行

(単位:千円 消費税抜)

口径 改定日	13mm	20mm	25mm	40mm	50mm	75mm	100mm	150mm	200mm以上
平成 21.4.1	60	90	180	600	1,140	2,880	5,400	10,800	管理者が別に定める

(消費税含む)

3 用途別使用水量状況

用途 年度期	一般用						湯屋用			福祉用			臨時用					
	水道事業(上・簡水合算)			旧上水道事業			旧簡易水道事業			件数	水量 m ³	料金 円	件数	水量 m ³	料金 円	件数	水量 m ³	料金 円
	件数	水量 m ³	料金 円	件数	水量 m ³	料金 円	件数	水量 m ³	料金 円									
24	486,858	19,459,931	3,835,482,658	485,426	19,396,253	3,823,107,135	1,432	63,678	12,375,523	-	-	-	173	267,984	35,237,658	41	890	481,792
25	492,442	19,340,387	3,806,753,826	490,858	19,274,088	3,793,416,282	1,584	66,299	13,337,544	-	-	-	164	270,667	35,940,382	17	645	348,774
26	497,154	18,999,433	3,823,775,691	495,462	18,932,275	3,809,664,206	1,692	67,158	14,111,485	-	-	-	164	267,397	36,564,440	23	578	321,476
27	501,910	19,114,785	3,861,284,375	500,156	19,042,650	3,845,513,539	1,754	72,135	15,770,836	-	-	-	165	272,934	36,987,355	27	677	376,537
28	507,384	19,229,836	3,892,637,060	-	-	-	-	-	-	-	-	-	160	245,392	32,635,136	4	829	461,088
29	514,464	19,178,250	3,881,110,582	-	-	-	-	-	-	-	-	-	150	240,673	32,625,570	9	545	303,126
30	519,570	19,052,950	3,853,887,077	-	-	-	-	-	-	-	-	-	145	234,444	30,987,592	11	494	274,760
4月	39,558	1,362,193	279,999,656	-	-	-	-	-	-	-	-	-	6	10,457	1,420,181	1	1	556
5月	46,670	1,751,851	352,946,776	-	-	-	-	-	-	-	-	-	18	28,204	3,699,462	1	1	556
6月	39,550	1,388,651	279,759,557	-	-	-	-	-	-	-	-	-	6	10,909	1,479,554	-	-	-
7月	46,653	1,801,688	364,295,684	-	-	-	-	-	-	-	-	-	18	29,595	3,901,919	2	4	2,224
8月	39,610	1,433,915	289,738,672	-	-	-	-	-	-	-	-	-	6	11,013	1,495,329	1	5	2,781
9月	46,764	1,879,164	381,396,248	-	-	-	-	-	-	-	-	-	18	28,802	3,776,623	1	10	5,562
10月	39,643	1,370,500	276,329,164	-	-	-	-	-	-	-	-	-	6	10,997	1,489,425	2	8	4,449
11月	46,752	1,763,168	354,715,857	-	-	-	-	-	-	-	-	-	18	27,835	3,630,866	2	464	258,076
12月	39,662	1,388,353	279,706,345	-	-	-	-	-	-	-	-	-	6	10,971	1,488,422	1	1	556
1月	46,836	1,765,895	354,231,553	-	-	-	-	-	-	-	-	-	18	28,171	3,693,775	-	-	-
2月	39,815	1,460,401	299,693,547	-	-	-	-	-	-	-	-	-	6	10,688	1,453,030	-	-	-
3月	48,057	1,687,171	341,074,018	-	-	-	-	-	-	-	-	-	19	26,802	3,459,006	-	-	-
30年度構成比	100.0	96.8	98.1	0.0	0.0	0.0	0.0	0.0	0.0	0.0	0.0	0.0	0.0	1.2	0.8	0.0	0.0	0.0
1件1か月の平均	-	18.3	3,709	-	-	-	-	-	-	-	-	-	-	808.4	106,854	-	22.5	12,489

※簡易水道事業は一般用のみ

(消費税含む)

用途 年度・期	工場用			水道事業合計(上・簡水合算)						旧上水道事業合計						旧簡易水道事業合計		
	件数	水量 m ³	料金 円	件数	水量 m ³	料金 円	件数	水量 m ³	料金 円	件数	水量 m ³	料金 円	件数	水量 m ³	料金 円	件数	水量 m ³	料金 円
	合 計																	
24	60	398,174	43,657,191	487,132	20,126,979	3,914,859,299	485,700	20,063,301	3,902,483,776	1,432	63,678	12,375,523						
25	65	391,003	44,018,152	492,688	20,002,702	3,887,061,134	491,104	19,936,403	3,873,723,590	1,584	66,299	13,337,544						
26	36	348,871	39,488,937	497,377	19,616,279	3,900,150,544	495,685	19,549,121	3,886,039,059	1,692	67,158	14,111,485						
27	36	358,059	40,578,131	502,138	19,746,455	3,939,226,398	500,384	19,674,320	3,923,455,562	1,754	72,135	15,770,836						
28	40	387,286	43,644,441	507,588	19,863,343	3,969,377,725	-	-	-	-	-	-						
29	36	389,719	43,926,975	514,659	19,809,187	3,957,966,253	-	-	-	-	-	-						
30	38	402,587	45,443,624	519,764	19,690,475	3,930,593,053	-	-	-	-	-	-						
4月	-	-	-	39,565	1,372,651	281,420,393	-	-	-	-	-	-						
5月	6	61,941	7,022,736	46,695	1,841,997	363,669,530	-	-	-	-	-	-						
6月	-	-	-	39,556	1,399,560	281,239,111	-	-	-	-	-	-						
7月	6	64,311	7,268,458	46,679	1,895,598	375,468,285	-	-	-	-	-	-						
8月	-	-	-	39,617	1,444,933	291,236,782	-	-	-	-	-	-						
9月	6	79,592	8,843,207	46,789	1,987,568	394,021,640	-	-	-	-	-	-						
10月	-	-	-	39,651	1,381,505	277,823,038	-	-	-	-	-	-						
11月	6	67,122	7,559,902	46,778	1,858,589	366,164,701	-	-	-	-	-	-						
12月	-	-	-	39,669	1,399,325	281,195,323	-	-	-	-	-	-						
1月	7	64,565	7,314,594	46,861	1,858,631	365,239,922	-	-	-	-	-	-						
2月	-	-	-	39,821	1,471,089	301,146,577	-	-	-	-	-	-						
3月	7	65,056	7,434,727	48,083	1,779,029	351,967,751	-	-	-	-	-	-						
30年度構成比	0.0	2.0	1.2	100.0	100.0	100.0	0.0	0.0	0.0	0.0	0.0	0.0	0.0	0.0	0.0	0.0	0.0	0.0
1件1か月の平均	-	5,297	597,942	-	18.9	3,781	-	-	-	-	-	-	-	-	-	-	-	-

※簡易水道事業は一般用のみ

単位(水量): m³
 単位(料金): 円(消費税含む)

4 口径別使用水量状況

		φ 13mm	φ 20mm	φ 25mm	φ 40mm	φ 50mm	φ 75mm	φ 100mm	φ 150mm	φ 200mm	φ 300mm	合計
		一般用	件数	257,901	238,211	15,150	6,038	1,602	510	133	12	13
	水量	6,530,343	7,230,126	1,080,955	2,224,283	968,717	609,580	347,748	36,808	24,390	-	19,052,950
	料金	1,252,137,005	1,347,387,260	233,046,314	511,683,496	234,545,585	169,523,416	88,497,868	10,333,697	6,732,436	-	3,853,887,077
湯屋用	件数	-	-	-	-	-	-	-	-	-	-	-
	水量	-	-	-	-	-	-	-	-	-	-	-
	料金	-	-	-	-	-	-	-	-	-	-	-
臨時用	件数	5	4	1	-	-	1	-	-	-	-	11
	水量	10	20	16	-	-	448	-	-	-	-	494
	料金	5,561	11,123	8,899	-	-	249,177	-	-	-	-	274,760
福祉用	件数	-	-	-	90	49	6	-	-	-	-	145
	水量	-	-	-	127,682	80,959	25,803	-	-	-	-	234,444
	料金	-	-	-	16,669,165	11,128,072	3,190,355	-	-	-	-	30,987,592
工場用	件数	-	-	-	12	-	20	6	-	-	-	38
	水量	-	-	-	9,109	-	354,766	38,712	-	-	-	402,587
	料金	-	-	-	2,136,224	-	38,693,048	4,614,352	-	-	-	45,443,624
合計	件数	257,906	238,215	15,151	6,140	1,651	537	139	12	13	-	519,764
	水量	6,530,353	7,230,146	1,080,971	2,361,074	1,049,676	990,597	386,460	36,808	24,390	-	19,690,475
	料金	1,252,142,566	1,347,398,383	233,055,213	530,488,885	245,673,657	211,655,996	93,112,220	10,333,697	6,732,436	-	3,930,593,053

5 検針業務状況

(単位:件)

区分 月別	人 員 (人)	検針件数	1人1ヶ月 平均件数	1人1ヶ月		検針不能
				最 高	最 低	
30年4月	15	42,224	2,814	3,975	855	7
5月	14	49,892	3,563	4,295	1,980	0
6月	15	42,407	2,827	3,980	897	9
7月	14	49,978	3,569	4,292	2,009	0
8月	15	42,494	2,832	3,985	895	9
9月	14	50,028	3,573	4,292	2,012	0
10月	15	42,606	2,840	3,992	891	10
11月	14	50,025	3,573	4,296	2,060	1
12月	15	42,663	2,844	3,994	888	10
31年1月	14	50,212	3,586	4,297	2,056	0
2月	15	42,655	2,843	3,992	889	6
3月	14	50,376	3,598	4,304	2,080	0
合 計	174	555,560	-	-	-	52
平 均	14	46,296	-	-	-	4

6 水道料金調定及び収入状況

【全体】

項目 月別	調定		未納分		収納		収納率	
	件数(件)	金額(円)	件数(件)	金額(円)	件数(件)	金額(円)	件数(%)	金額(%)
30年4月	39,565	281,420,393	81	283,032	39,484	281,137,361	99.80	99.90
5月	46,695	363,669,530	86	279,318	46,609	363,390,212	99.82	99.92
6月	39,556	281,239,111	80	270,517	39,476	280,968,594	99.80	99.90
7月	46,679	375,468,285	83	305,722	46,596	375,162,563	99.82	99.92
8月	39,617	291,236,782	94	308,377	39,523	290,928,405	99.76	99.89
9月	46,789	394,021,640	99	381,294	46,690	393,640,346	99.79	99.90
10月	39,651	277,823,038	112	472,488	39,539	277,350,550	99.72	99.83
11月	46,778	366,164,701	137	562,507	46,641	365,602,194	99.71	99.85
12月	39,669	281,195,323	427	2,342,987	39,242	278,852,336	98.92	99.17
31年1月	46,861	365,239,922	2,147	12,004,496	44,714	353,235,426	95.42	96.71
2月	39,821	301,146,577	6,082	48,421,044	33,739	252,725,533	84.73	83.92
3月	48,083	351,967,751	47,955	351,637,916	128	329,835	0.27	0.09
計	519,764	3,930,593,053	57,383	417,269,698	462,381	3,513,323,355	88.96	89.38

【口座制】

項目 月別	調 定		未 納 分		収 納		収 納 率	
	件数(件)	金額(円)	件数(件)	金額(円)	件数(件)	金額(円)	件数(%)	金額(%)
30年4月	32,379	238,139,213	17	40,089	32,362	238,099,124	99.95	99.98
5月	38,022	290,477,495	12	38,436	38,010	290,439,059	99.97	99.99
6月	32,434	226,273,694	9	23,209	32,425	226,250,485	99.97	99.99
7月	38,092	295,295,590	12	35,326	38,080	295,260,264	99.97	99.99
8月	32,464	234,938,300	18	57,088	32,446	234,881,212	99.94	99.98
9月	38,102	310,426,027	16	75,509	38,086	310,350,518	99.96	99.98
10月	32,449	228,764,236	14	73,087	32,435	228,691,149	99.96	99.97
11月	38,119	292,588,391	27	101,441	38,092	292,486,950	99.93	99.97
12月	32,447	230,898,120	82	560,427	32,365	230,337,693	99.75	99.76
31年1月	38,150	293,834,580	597	4,007,738	37,553	289,826,842	98.44	98.64
2月	32,542	251,751,371	2,242	26,799,175	30,300	224,952,196	93.11	89.35
3月	38,880	278,230,190	38,865	278,188,028	15	42,162	0.04	0.02
計	424,080	3,171,617,207	41,911	309,999,553	382,169	2,861,617,654	90.12	90.23

【納付制】

項目 月別	調 定		未 納 分		収 納				収 納 率	
	件数(件)	金額(円)	件数(件)	金額(円)	件数(件)	金額(円)	コンビニ収納		件数(%)	金額(%)
30年4月	7,186	43,281,180	64	242,943	7,122	43,038,237	4,684	19,200,941	99.11	99.44
5月	8,673	73,192,035	74	240,882	8,599	72,951,153	5,256	22,995,628	99.15	99.67
6月	7,122	54,965,417	71	247,308	7,051	54,718,109	4,576	19,894,293	99.00	99.55
7月	8,587	80,172,695	71	270,396	8,516	79,902,299	5,259	23,171,147	99.17	99.66
8月	7,153	56,298,482	76	251,289	7,077	56,047,193	4,631	20,418,422	98.94	99.55
9月	8,687	83,595,613	83	305,785	8,604	83,289,828	5,244	23,982,522	99.04	99.63
10月	7,202	49,058,802	98	399,401	7,104	48,659,401	4,711	20,291,367	98.64	99.19
11月	8,659	73,576,310	110	461,066	8,549	73,115,244	5,396	23,764,367	98.73	99.37
12月	7,222	50,297,203	345	1,782,560	6,877	48,514,643	4,676	20,487,992	95.22	96.46
31年1月	8,711	71,405,342	1,550	7,996,758	7,161	63,408,584	5,240	23,032,469	82.21	88.80
2月	7,279	49,395,206	3,840	21,621,869	3,439	27,773,337	2,714	9,218,178	47.25	56.23
3月	9,203	73,737,561	9,090	73,449,888	113	287,673	27	49,734	1.23	0.39
計	95,684	758,975,846	15,472	107,270,145	80,212	651,705,701	52,414	226,507,060	83.83	85.87