

第3章. 上水道編

第5節 業務統計

1 配水分析

上段:上・簡水合算
中段:上水道事業
下段:簡易水道事業

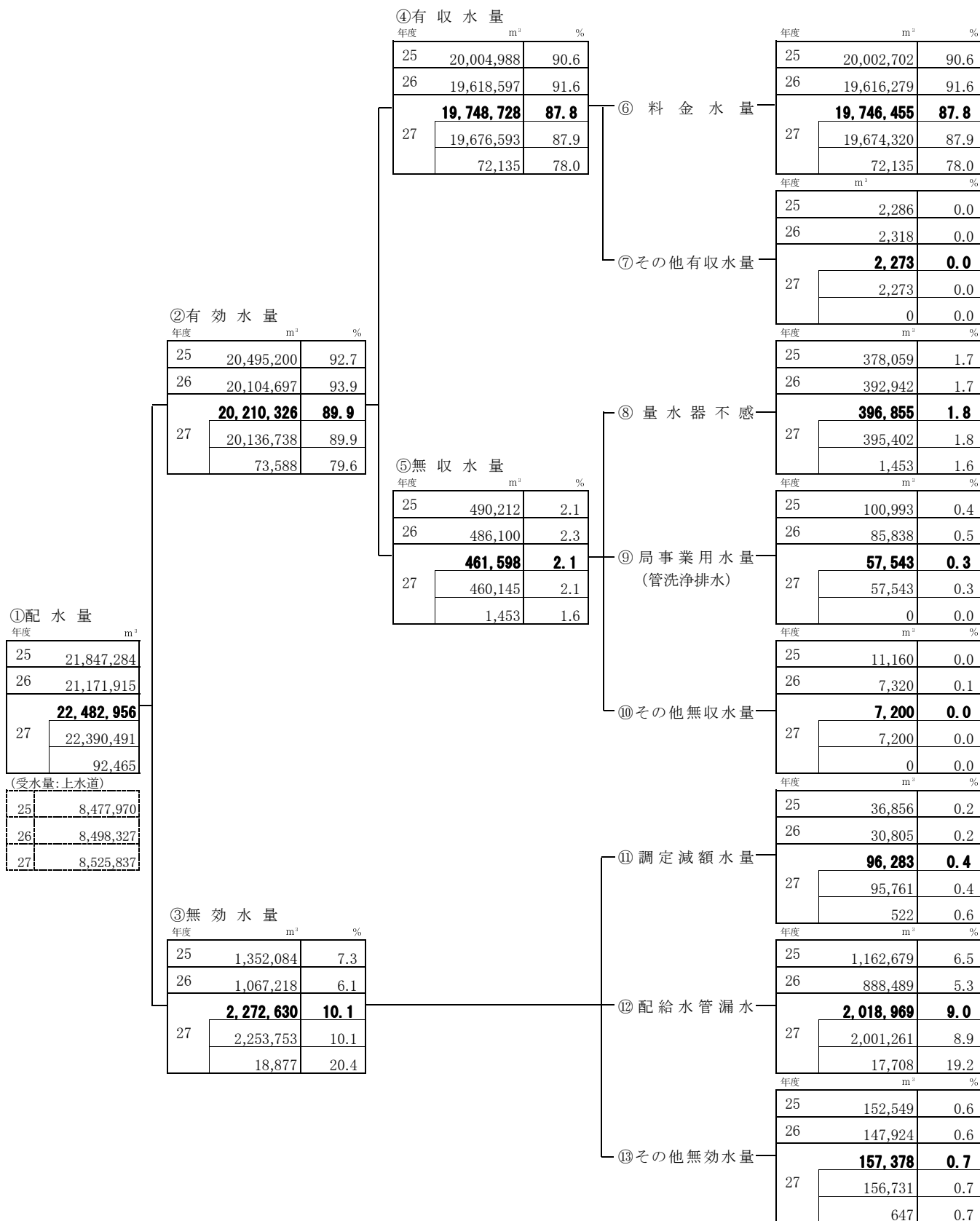

2 加入金の推移と変遷

(1) 加入金の推移

上段：上・簡水合算

中段：上水道事業

下段：簡易水道事業

単位(件数):件

単位(金額):千円

口径 区分	年度	23		24		25		26		27	
		件数	構成比 (%)	件数	構成比 (%)	件数	構成比 (%)	件数	構成比 (%)	件数	構成比 (%)
13mm	件数	360	37.7	555	41.7	599	45.2	621	41.3	859	58.4
		354	37.3	552	41.6	599	45.2	617	41.2	858	58.4
		6	75.0	3	50.0	0	0.0	4	80.0	1	50.0
	金額	22,680	26.8	34,965	28.1	37,737	30.1	40,221	29.1	55,663	41.7
		22,302	26.7	34,776	28.1	37,737	30.1	39,962	29.7	55,598	41.7
		378	34.3	189	40.0	0	0.0	259	7.7	65	40.0
20mm	件数	464	48.5	614	46.1	589	44.4	721	48.0	526	35.8
		463	48.8	611	46.1	588	44.4	721	48.2	525	35.7
		1	12.5	3	50.0	1	100.0	0	0.0	1	50.0
	金額	43,848	51.7	58,024	46.7	55,661	44.3	70,081	50.8	51,127	38.3
		43,753	52.3	57,740	46.7	55,566	44.3	70,081	52.0	51,030	38.3
		95	8.6	284	60.0	95	100.0	0	0.0	97	60.0
25mm	件数	18	1.9	11	0.8	31	2.3	27	1.8	34	2.3
		18	1.9	11	0.8	31	2.3	27	1.8	34	2.3
		0	0.0	0	0.0	0	0.0	0	0.0	0	0.0
	金額	3,402	4.0	2,079	1.7	5,859	4.7	5,249	3.8	6,610	5.0
		3,402	4.1	2,079	1.7	5,859	4.7	5,249	3.9	6,610	5.0
		0	0.0	0	0.0	0	0.0	0	0.0	0	0.0
40mm	件数	4	0.4	4	0.3	7	0.5	4	0.3	9	0.6
		3	0.3	3	0.2	7	0.5	4	0.3	9	0.6
		1	12.5	1	16.7	0	0.0	0	0.0	0	0.0
	金額	2,520	3.0	8,190	6.6	4,410	3.5	2,592	1.9	5,832	4.4
		1,890	2.3	8,190	6.6	4,410	3.5	2,592	1.9	5,832	4.4
		630	57.1	0	0.0	0	0.0	0	0.0	0	0.0
50mm	件数	0	0.0	2	0.2	5	0.4	1	0.1	3	0.2
		0	0.0	2	0.2	5	0.4	1	0.1	3	0.2
		0	0.0	0	0.0	0	0.0	0	0.0	0	0.0
	金額	0	0.0	2,394	1.9	5,985	4.8	1,231	0.9	3,694	2.8
		0	0.0	2,394	1.9	5,985	4.8	1,231	0.9	3,694	2.8
		0	0.0	0	0.0	0	0.0	0	0.0	0	0.0
75mm	件数	0	0.0	1	0.1	1	0.1	1	0.1	0	0.0
		0	0.0	1	0.1	1	0.1	0	0.0	0	0.0
		0	0.0	0	0.0	0	0.0	1	20.0	0	0.0
	金額	0	0.0	3,024	2.4	3,024	2.4	3,110	2.3	0	0.0
		0	0.0	3,024	2.4	3,024	2.4	0	0.0	0	0.0
		0	0.0	0	0.0	0	0.0	3,110	92.3	0	0.0
100mm	件数	0	0.0	0	0.0	0	0.0	0	0.0	0	0.0
		0	0.0	0	0.0	0	0.0	0	0.0	0	0.0
		0	0.0	0	0.0	0	0.0	0	0.0	0	0.0
	金額	0	0.0	0	0.0	0	0.0	0	0.0	0	0.0
		0	0.0	0	0.0	0	0.0	0	0.0	0	0.0
		0	0.0	0	0.0	0	0.0	0	0.0	0	0.0
小計	件数	846	88.5	1,196	89.8	1,232	92.9	1,375	91.5	1,431	97.3
		838	88.4	1,190	89.7	1,231	92.9	1,370	91.5	1,429	97.3
		8	100.0	6	100.0	1	100.0	5	100.0	2	100.0
	金額	72,450	85.5	108,676	87.5	112,676	89.7	122,485	88.7	122,926	92.1
		71,347	85.3	108,203	87.4	112,581	89.7	119,115	88.5	122,764	92.1
		1,103	100.0	473	100.0	95	100.0	3,370	100.0	162	100.0
口径変更	件数	110	11.5	136	10.2	94	7.1	127	8.5	40	2.7
		110	11.6	136	10.3	94	7.1	127	8.5	40	2.7
		0	0.0	0	0.0	0	0.0	0	0.0	0	0.0
	金額	12,285	14.5	15,561	12.5	12,883	10.3	15,552	11.3	10,498	7.9
		12,285	14.7	15,561	12.6	12,883	10.3	15,552	11.5	10,498	7.9
		0	0.0	0	0.0	0	0.0	0	0.0	0	0.0
合計	件数	956	100.0	1,332	100.0	1,326	100.0	1,502	100.0	1,471	100.0
		948	100.0	1,326	100.0	1,325	100.0	1,497	100.0	1,469	100.0
		8	100.0	6	100.0	1	100.0	5	100.0	2	100.0
	金額	84,735	100.0	124,237	100.0	125,559	100.0	138,037	100.0	133,423	100.0
		83,632	100.0	123,764	100.0	125,464	100.0	134,667	100.0	133,261	100.0
		1,103	100.0	473	100.0	95	100.0	3,370	100.0	162	100.0

(2) 加入金の変遷

【上水道事業】

旧佐賀市

(単位:千円 消費税抜)

口径 改定日	13mm	20mm	25mm	40mm	50mm	75mm	100mm	150mm	200mm以上
昭和55. 4. 1	30	40	70	220	390	900	1,900	150mm 以上は管 理者が別 に定める	
59. 4. 1	40	60	120	400	800	2,000	3,800		
63. 4. 1	50	75	150	500	950	2,400	4,500		
平成 4.12. 1	60	90	180	600	1,140	2,880	5,400		
9.10. 1	60	90	180	600	1,140	2,880	5,400	10,800	管理者が別に定める

旧大和町

(単位:千円 消費税抜)

口径 改定日	13mm	20mm	25mm	40mm	50mm	75mm	100mm	150mm
平成 4.4.1	120	168	287	777	1,360	3,059	5,437	町長が定める

新佐賀市

(単位:千円 消費税抜)

口径 改定日	13mm	20mm	25mm	40mm	50mm	75mm	100mm	150mm	200mm以上
平成 18.4.1	60	90	180	600	1,140	2,880	5,400	10,800	管理者が別に定める

【簡易水道事業】

大和簡易水道・大和飲料水供給施設

(単位:千円 消費税抜)

口径 改定日	13mm	20mm	25mm	40mm	50mm	75mm	100mm	150mm	200mm以上
平成 10.12.24	120	168	287	777	1,360	3,059	5,437	町長が定 める	-
平成 18.4.1	佐賀市水道事業の給水条例の規定の例による								

富士南部簡易水道

(単位:千円 消費税抜)

口径 改定日	13mm	20mm	25mm	40mm	50mm	75mm	100mm	150mm	200mm以上
平成 16.4.1	120	168	-	-	-	-	-	-	-
平成 18.4.1	佐賀市水道事業の給水条例の規定の例による								

【上水道・簡易水道事業】

現行

(単位:千円 消費税抜)

口径 改定日	13mm	20mm	25mm	40mm	50mm	75mm	100mm	150mm	200mm以上
平成 21.4.1	60	90	180	600	1,140	2,880	5,400	10,800	管理者が別に定める

3 用途別使用水量状況

(消費税含む)

用途 年度・期	一 般 用						湯 屋 用			福 祉 用			臨 時 用					
	上・簡水合算			上水道事業			簡易水道事業			件数	水量 m ³	料金 円	件数	水量 m ³	料金 円	件数	水量 m ³	料金 円
	件数 件	水量 m ³	料金 円	件数 件	水量 m ³	料金 円	件数 件	水量 m ³	料金 円									
21	472,970	19,740,019	3,960,656,875	472,970	19,740,019	3,960,656,875	1,143	53,667	9,218,263	5	107	15,166	187	260,712	33,799,748	29	937	506,670
22	475,759	19,745,901	3,957,680,002	475,759	19,745,901	3,957,680,002	1,161	56,349	9,664,002	1	2	283	217	276,126	35,958,154	32	1,109	599,677
23	476,920	19,802,250	3,967,344,004	521,909	21,229,294	4,202,732,725	1,367	67,198	12,375,975	-	-	-	246	314,633	40,370,380	58	1,088	588,313
24	523,276	21,296,492	4,215,108,700	485,426	19,396,253	3,823,107,135	1,432	63,678	12,375,523	-	-	-	173	267,984	35,237,658	41	890	481,792
25	492,442	19,340,387	3,806,753,826	490,858	19,274,088	3,793,416,282	1,584	66,299	13,337,544	-	-	-	164	270,667	35,940,382	17	645	348,774
26	497,154	18,999,433	3,823,775,691	495,462	18,932,275	3,809,664,206	1,692	67,158	14,111,485	-	-	-	164	267,397	36,564,440	23	578	321,476
27	501,910	19,114,785	3,861,284,375	500,156	19,042,650	3,845,513,539	1,754	72,135	15,770,836	-	-	-	165	272,934	36,987,355	27	677	376,537
4月	38,672	1,372,261	282,061,900	38,672	1,372,261	282,061,900	-	-	-	-	-	-	7	11,889	1,646,424	2	5	2,780
5月	44,706	1,739,083	349,887,115	44,416	1,727,567	347,428,375	290	11,516	2,458,740	-	-	-	20	33,541	4,613,348	-	-	-
6月	38,646	1,389,150	278,323,453	38,643	1,389,139	278,316,001	3	11	7,452	-	-	-	7	11,860	1,641,237	3	56	31,146
7月	44,659	1,783,591	360,863,506	44,371	1,772,048	358,340,421	288	11,543	2,523,085	-	-	-	20	31,861	4,285,405	2	3	1,668
8月	38,704	1,423,837	285,954,867	38,704	1,423,837	285,954,867	-	-	-	-	-	-	7	12,488	1,722,851	4	71	39,490
9月	44,832	1,830,435	370,723,976	44,541	1,818,727	368,220,236	291	11,708	2,503,740	-	-	-	20	32,344	4,326,638	1	2	1,112
10月	38,762	1,386,533	278,233,635	38,762	1,386,533	278,233,635	-	-	-	-	-	-	7	12,543	1,722,094	3	36	20,022
11月	44,707	1,796,332	362,234,101	44,414	1,784,349	359,576,994	293	11,983	2,657,107	-	-	-	21	33,539	4,488,931	5	463	257,519
12月	38,704	1,399,773	282,169,437	38,703	1,399,765	282,166,953	1	8	2,484	-	-	-	6	12,008	1,661,535	3	16	8,897
1月	44,708	1,769,718	356,010,591	44,416	1,757,289	353,247,403	292	12,429	2,763,188	-	-	-	21	33,418	4,483,755	2	15	8,342
2月	38,930	1,482,308	301,876,212	38,929	1,482,290	301,873,167	1	18	3,045	-	-	-	6	12,787	1,776,047	1	6	3,337
3月	45,880	1,741,764	352,945,582	45,585	1,728,845	350,093,587	295	12,919	2,851,995	-	-	-	23	34,656	4,619,090	1	4	2,224
27年度構成比	100.0	96.8	98.0	99.6	96.4	97.6	0.4	0.4	0.4	0.0	0.0	0.0	0.0	1.4	0.9	0.0	0.0	0.0
1件1か月の平均	-	19.0	3,847	-	19.0	3,844	-	20.6	4,496	-	-	-	-	827.1	112,083	-	12.5	6,973

※簡易水道事業は一般用のみ

(消費税含む)

用途 年度・期	工場用						合 計					
	上・簡水合算			水道事業合計			簡易水道事業合計			水道事業合計		
	件数	水量 m ³	料金 円	件数	水量 m ³	料金 円	件数	水量 m ³	料金 円	件数	水量 m ³	料金 円
21	30	298,741	33,423,731	474,364	20,354,183	4,037,620,453	473,221	20,300,516	4,028,402,190	1,143	53,667	9,218,263
22	30	315,434	35,106,383	477,200	20,394,921	4,039,008,501	476,039	20,338,572	4,029,344,499	1,161	56,349	9,664,002
23	35	418,733	45,745,197	477,200	20,394,921	4,039,008,501	476,039	20,338,572	4,029,344,499	1,367	67,198	12,375,975
24	60	398,174	43,657,191	523,615	22,030,946	4,301,812,590	522,248	21,963,748	4,289,436,615	1,432	63,678	12,375,523
25	65	391,003	44,018,152	492,688	20,002,702	3,887,061,134	491,104	19,936,403	3,873,723,590	1,584	66,299	13,337,544
26	36	348,871	39,488,937	497,377	19,616,279	3,900,150,544	495,685	19,549,121	3,886,039,059	1,692	67,158	14,111,485
27	36	358,059	40,578,131	502,138	19,746,455	3,939,226,398	500,384	19,674,320	3,923,455,562	1,754	72,135	15,770,836
4月	-	-	-	38,681	1,384,155	283,711,104	38,681	1,384,155	283,711,104	-	-	-
5月	6	55,093	6,283,984	44,732	1,827,717	360,784,447	44,442	1,816,201	358,325,707	290	11,516	2,458,740
6月	-	-	-	38,656	1,401,066	279,995,836	38,653	1,401,055	279,988,384	3	11	7,452
7月	6	62,245	7,018,925	44,687	1,877,700	372,169,504	44,399	1,866,157	369,646,419	288	11,543	2,523,085
8月	-	-	-	38,715	1,436,396	287,717,208	38,715	1,436,396	287,717,208	-	-	-
9月	6	69,661	7,788,004	44,859	1,932,442	382,839,730	44,568	1,920,734	380,335,990	291	11,708	2,503,740
10月	-	-	-	38,772	1,399,112	279,975,751	38,772	1,399,112	279,975,751	-	-	-
11月	6	62,904	7,095,332	44,739	1,893,238	374,075,883	44,446	1,881,255	371,418,776	293	11,983	2,657,107
12月	-	-	-	38,713	1,411,797	283,839,869	38,712	1,411,789	283,837,385	1	8	2,484
1月	6	53,168	6,090,037	44,737	1,856,319	366,592,725	44,445	1,843,890	363,829,537	292	12,429	2,763,188
2月	-	-	-	38,937	1,495,101	303,655,596	38,936	1,495,083	303,652,551	1	18	3,045
3月	6	54,988	6,301,849	45,910	1,831,412	363,868,745	45,615	1,818,493	361,016,750	295	12,919	2,851,995
27年度構成比	0.0	1.8	1.0	100.0	100.0	100.0	99.7	99.6	99.6	0.4	0.4	0.4
1件1か月の平均	-	4,973	563,585	-	19.7	3,922	-	19.7	3,920	-	20.6	4,496

※簡易水道事業は一般用のみ

4 口径別使用水量状況

単位(水量): m³
 単位(料金): 円 (消費税含む)

	φ13mm	φ20mm	φ25mm	φ40mm	φ50mm	φ75mm	φ100mm	φ150mm	φ200mm	φ300mm	合計
上・簡水合算	251,253	228,032	14,506	5,894	1,577	517	106	12	13	-	501,910
水量	6,589,790	7,137,841	1,127,240	2,228,720	1,024,069	636,598	289,432	45,449	35,646	-	19,114,785
料金	1,254,857,136	1,327,293,594	244,440,584	511,387,015	249,237,800	176,338,546	75,279,608	12,381,430	10,068,662	-	3,861,284,375
一般用	249,783	227,802	14,494	5,870	1,565	511	106	12	13	-	500,156
水道事業	6,551,247	7,131,014	1,126,858	2,226,163	1,003,837	633,004	289,432	45,449	35,646	-	19,042,650
料金	1,247,657,988	1,326,107,453	244,367,147	510,872,453	243,412,444	175,366,354	75,279,608	12,381,430	10,068,662	-	3,845,513,539
簡易水道事業	1,470	230	12	24	12	6	-	-	-	-	1,754
水量	38,543	6,827	382	2,557	20,232	3,594	-	-	-	-	72,135
料金	7,199,148	1,186,141	73,437	514,562	5,825,356	972,192	-	-	-	-	15,770,836
湯屋用	-	-	-	-	-	-	-	-	-	-	-
水量	-	-	-	-	-	-	-	-	-	-	-
料金	-	-	-	-	-	-	-	-	-	-	-
臨時用	21	4	1	-	-	1	-	-	-	-	27
水量	212	10	13	-	-	442	-	-	-	-	677
料金	117,906	5,561	7,230	-	-	245,840	-	-	-	-	376,537
福祉用	-	-	6	101	52	6	-	-	-	-	165
水量	-	-	30	143,174	89,987	39,743	-	-	-	-	272,934
料金	-	-	3,075	19,551,263	12,372,615	5,060,402	-	-	-	-	36,987,355
工場用	-	-	-	12	-	18	6	-	-	-	36
水量	-	-	-	7,408	-	318,131	32,520	-	-	-	358,059
料金	-	-	-	1,819,864	-	34,785,900	3,972,367	-	-	-	40,578,131
上・簡水合算	251,274	228,036	14,513	6,007	1,629	542	112	12	13	-	502,138
水量	6,590,002	7,137,851	1,127,283	2,379,302	1,114,056	994,914	321,952	45,449	35,646	-	19,746,455
料金	1,254,975,042	1,327,299,155	244,450,889	532,758,142	261,610,415	216,430,688	79,251,975	12,381,430	10,068,662	-	3,939,226,398
一般用	249,804	227,806	14,501	5,983	1,617	536	112	12	13	-	500,384
水道事業	6,551,459	7,131,024	1,126,901	2,376,745	1,093,824	991,320	321,952	45,449	35,646	-	19,674,320
料金	1,247,775,894	1,326,113,014	244,377,452	532,243,580	255,785,059	215,458,496	79,251,975	12,381,430	10,068,662	-	3,923,455,562
簡易水道事業	1,470	230	12	24	12	6	-	-	-	-	1,754
水量	38,543	6,827	382	2,557	20,232	3,594	-	-	-	-	72,135
料金	7,199,148	1,186,141	73,437	514,562	5,825,356	972,192	-	-	-	-	15,770,836

5 検針業務状況

上段：上・簡水合算

中段：上水道事業

下段：簡易水道事業

(単位:件)

区分 月別	人員 (人)	検針件数	1人1ヶ月 平均件数	1人1ヶ月		検針不能
				最高	最低	
27年4月	15	41,125	2,741	4,101	1,740	2
	15	41,125	2,741	4,101	1,740	2
	-	-	-	-	-	-
5月	17	47,708	2,806	4,431	1,831	0
	14	47,391	3,385	4,431	1,831	0
	3	317	105	-	-	0
6月	15	41,183	2,745	4,104	1,739	2
	15	41,183	2,745	4,104	1,739	2
	-	-	-	-	-	-
7月	17	47,701	2,805	4,435	1,842	0
	14	47,383	3,384	4,435	1,842	0
	3	318	106	-	-	0
8月	15	41,144	2,742	4,100	1,738	4
	15	41,144	2,742	4,100	1,738	4
	-	-	-	-	-	-
9月	17	47,797	2,811	4,208	1,855	0
	14	47,479	3,391	4,208	1,855	0
	3	318	106	-	-	0
10月	15	41,229	2,748	3,896	1,771	1
	15	41,229	2,748	3,896	1,771	1
	-	-	-	-	-	-
11月	17	47,849	2,814	4,215	1,878	0
	14	47,543	3,395	4,215	1,878	0
	3	306	102	-	-	0
12月	15	41,276	2,751	3,884	1,766	2
	15	41,276	2,751	3,884	1,766	2
	-	-	-	-	-	-
28年1月	17	47,900	2,817	4,210	1,880	0
	14	47,593	3,399	4,210	1,880	0
	3	307	102	-	-	0
2月	15	42,270	2,818	4,393	1,767	1
	15	42,270	2,818	4,393	1,767	1
	-	-	-	-	-	-
3月	17	48,175	2,833	4,240	1,883	0
	14	47,866	3,419	4,240	1,883	0
	3	309	103	-	-	0
合計	-	535,357	-	-	-	12
	-	533,482	-	-	-	12
	-	1,875	-	-	-	0
平均	16	44,613	2,788	4,185	1,808	1
	15	44,457	3,065	4,185	1,808	1
	3	313	104	-	-	0

6 水道料金調定及び収入状況

上段：上・簡水合算
中段：上水道事業
下段：簡易水道事業

【全体】

項目 月別	調定		未納分		収納		収納率	
	件数(件)	金額(円)	件数(件)	金額(円)	件数(件)	金額(円)	件数(%)	金額(%)
27年4月	38,681	283,711,104	75	285,372	38,606	283,425,732	99.81	99.90
	38,681	283,711,104	75	285,372	38,606	283,425,732	99.81	99.90
	0	0	0	0	0	0	-	-
5月	44,732	360,784,447	84	332,518	44,649	360,451,929	99.81	99.91
	44,442	358,325,707	84	332,518	44,359	357,993,189	99.81	99.91
	290	2,458,740	0	0	290	2,458,740	100.00	100.00
6月	38,656	279,995,836	75	236,252	38,581	279,759,584	99.81	99.92
	38,653	279,988,384	75	236,252	38,578	279,752,132	99.81	99.92
	3	7,452	0	0	3	7,452	100.00	100.00
7月	44,687	372,169,504	75	341,154	44,612	371,828,350	99.83	99.91
	44,399	369,646,419	75	341,154	44,324	369,305,265	99.83	99.91
	288	2,523,085	0	0	288	2,523,085	100.00	100.00
8月	38,715	287,717,208	84	291,166	38,631	287,426,042	99.78	99.90
	38,715	287,717,208	84	291,166	38,631	287,426,042	99.78	99.90
	0	0	0	0	0	0	-	-
9月	44,859	382,839,730	100	451,659	44,768	382,388,071	99.80	99.88
	44,568	380,335,990	98	443,084	44,479	379,892,906	99.80	99.88
	291	2,503,740	2	8,575	289	2,495,165	99.31	99.66
10月	38,772	279,975,751	153	760,391	38,619	279,215,360	99.61	99.73
	38,772	279,975,751	153	760,391	38,619	279,215,360	99.61	99.73
	0	0	0	0	0	0	-	-
11月	44,739	374,075,883	123	580,254	44,616	373,424,331	99.72	99.83
	44,446	371,418,776	121	575,286	44,325	370,843,490	99.73	99.85
	293	2,657,107	2	4,968	291	2,580,841	99.32	97.13
12月	38,713	283,839,869	449	2,567,456	38,264	281,272,413	98.84	99.10
	38,712	283,837,385	449	2,567,456	38,263	281,269,929	98.84	99.10
	1	2,484	0	0	1	2,484	-	-
28年1月	44,737	366,592,725	1,995	11,826,350	42,742	354,766,375	95.54	96.77
	44,445	363,829,537	1,980	11,757,720	42,465	352,071,817	95.55	96.77
	292	2,763,188	15	68,630	277	2,694,558	94.86	97.52
2月	38,937	303,655,596	8,187	66,332,574	30,750	237,323,022	78.97	78.16
	38,936	303,652,551	8,187	66,332,574	30,749	237,319,977	78.97	78.16
	1	3,045	0	0	1	3,045	-	-
3月	45,910	363,868,745	45,743	363,351,656	167	517,089	0.36	0.14
	45,615	361,016,750	45,448	360,499,661	167	517,089	0.37	0.14
	295	2,851,995	295	2,851,995	0	0	0.00	0.00
計	502,138	3,939,226,398	57,143	447,356,802	445,005	3,491,798,298	88.62	88.64
	500,384	3,923,455,562	56,829	444,422,634	443,565	3,479,032,928	88.64	88.67
	1,754	15,770,836	314	2,934,168	1,440	12,765,370	82.10	80.94

上段：上・簡水合算
 中段：上水道事業
 下段：簡易水道事業

【口座制】

項目 月別	調 定		未 納 分		収 納		収 納 率	
	件数(件)	金額(円)	件数(件)	金額(円)	件数(件)	金額(円)	件数(%)	金額(%)
27年4月	32,287	241,611,302	19	103,440	32,268	241,507,862	99.94	99.96
	32,287	241,611,302	19	103,440	32,268	241,507,862	99.94	99.96
	0	0	0	0	0	0	-	-
5月	36,872	288,854,163	16	70,004	36,857	288,784,159	99.96	99.98
	36,659	286,932,548	16	70,004	36,644	286,862,544	99.96	99.98
	213	1,921,615	0	0	213	1,921,615	100.00	100.00
6月	32,333	229,369,125	14	39,170	32,319	229,329,955	99.96	99.98
	32,331	229,364,157	14	39,170	32,317	229,324,987	99.96	99.98
	2	4,968	0	0	2	4,968	-	-
7月	36,914	292,029,000	11	56,718	36,903	291,972,282	99.97	99.98
	36,704	290,121,307	11	56,718	36,693	290,064,589	99.97	99.98
	210	1,907,693	0	0	210	1,907,693	100.00	100.00
8月	32,363	234,083,713	15	40,230	32,348	234,043,483	99.95	99.98
	32,363	234,083,713	15	40,230	32,348	234,043,483	99.95	99.98
	0	0	0	0	0	0	-	-
9月	37,011	301,027,260	24	141,924	36,996	300,885,336	99.96	99.95
	36,799	299,041,229	24	141,924	36,784	298,899,305	99.96	99.95
	212	1,986,031	0	0	212	1,986,031	100.00	100.00
10月	32,411	231,498,429	17	119,005	32,394	231,379,424	99.95	99.95
	32,411	231,498,429	17	119,005	32,394	231,379,424	99.95	99.95
	0	0	0	0	0	0	-	-
11月	36,912	298,539,287	20	80,458	36,892	298,458,829	99.95	99.97
	36,696	296,514,712	20	80,458	36,676	296,434,254	99.95	99.97
	216	2,024,575	0	0	216	2,024,575	100.00	100.00
12月	32,403	233,465,874	98	599,253	32,305	232,866,621	99.70	99.74
	32,403	233,465,874	98	599,253	32,305	232,866,621	99.70	99.74
	0	0	0	0	0	0	-	-
28年1月	36,909	296,260,595	591	4,061,213	36,318	292,199,382	98.40	98.63
	36,694	294,092,597	589	4,049,971	36,105	290,042,626	98.39	98.62
	215	2,167,998	2	11,242	213	2,156,756	99.07	99.48
2月	32,520	255,008,831	4,720	45,613,522	27,800	209,395,309	85.49	82.11
	32,520	255,008,831	4,720	45,613,522	27,800	209,395,309	85.49	82.11
	0	0	0	0	0	0	-	-
3月	37,675	288,752,168	37,647	288,660,160	28	92,008	0.07	0.03
	37,449	286,459,204	37,421	286,367,196	28	92,008	0.07	0.03
	226	2,292,964	226	2,292,964	0	0	0.00	0.00
計	416,610	3,190,499,747	43,192	339,585,097	373,428	2,850,914,650	89.63	89.36
	415,316	3,178,193,903	42,964	337,280,891	372,362	2,840,913,012	89.66	89.39
	1,294	12,305,844	228	2,304,206	1,066	10,001,638	82.38	81.28

【納付制】

項目 月別	調定		未納分		収納		コンビニ収納		収納率	
	件数(件)	金額(円)	件数(件)	金額(円)	件数(件)	金額(円)	件数(件)	金額(円)	件数(%)	金額(%)
27年4月	6,394	42,099,802	56	181,932	6,338	41,917,870	3,662	15,527,138	99.12	99.57
	6,394	42,099,802	56	181,932	6,338	41,917,870	3,662	15,527,138	99.12	99.57
	0	0	0	0	0	0	0	0	-	-
5月	7,860	71,930,284	68	262,514	7,792	71,667,770	4,724	22,251,039	99.13	99.64
	7,783	71,393,159	68	262,514	7,715	71,130,645	4,694	22,068,446	99.13	99.63
	77	537,125	0	0	77	537,125	30	182,593	100.00	100.00
6月	6,323	50,626,711	61	197,082	6,262	50,429,629	3,625	16,460,752	99.04	99.61
	6,322	50,624,227	61	197,082	6,261	50,427,145	3,625	16,460,752	99.04	99.61
	1	2,484	0	0	1	2,484	0	0	100.00	100.00
7月	7,773	80,140,504	64	284,436	7,709	79,856,068	4,620	21,876,927	99.18	99.65
	7,695	79,525,112	64	284,436	7,631	79,240,676	4,592	21,705,820	99.17	99.64
	78	615,392	0	0	78	615,392	28	171,107	100.00	100.00
8月	6,352	53,633,495	69	250,936	6,283	53,382,559	3,676	17,117,636	98.91	99.53
	6,352	53,633,495	69	250,936	6,283	53,382,559	3,676	17,117,636	98.91	99.53
	0	0	0	0	0	0	0	0	-	-
9月	7,848	81,812,470	76	309,735	7,772	81,502,735	4,738	23,067,578	99.03	99.62
	7,769	81,294,761	74	301,160	7,695	80,993,601	4,723	22,972,002	99.05	99.63
	79	517,709	2	8,575	77	509,134	15	95,576	97.47	98.34
10月	6,361	48,477,322	136	641,386	6,225	47,835,936	3,790	18,157,556	97.86	98.68
	6,361	48,477,322	136	641,386	6,225	47,835,936	3,790	18,157,556	97.86	98.68
	0	0	0	0	0	0	0	0	-	-
11月	7,807	75,465,298	103	499,796	7,704	74,965,502	4,793	22,987,883	98.68	99.34
	7,750	74,904,064	101	494,828	7,649	74,409,236	4,756	22,767,565	98.70	99.34
	77	632,532	2	4,968	75	627,564	37	220,318	97.40	99.21
12月	6,330	50,445,293	351	1,968,203	5,979	48,477,090	3,777	17,852,998	94.45	96.10
	6,309	50,371,511	351	1,968,203	5,958	48,403,308	3,776	17,850,514	94.44	96.09
	1	2,484	0	0	1	2,484	1	2,484	-	-
28年1月	7,828	70,332,130	1,404	7,765,137	6,424	62,566,993	4,523	21,388,154	82.06	88.96
	7,751	69,736,940	1,391	7,707,749	6,360	62,029,191	4,497	21,228,545	82.05	88.95
	77	595,190	13	57,388	64	537,802	26	159,609	83.12	90.36
2月	6,417	48,646,765	3,467	20,719,052	2,950	27,927,713	1,808	7,462,263	45.97	57.41
	6,416	48,643,720	3,467	20,719,052	2,949	27,924,668	1,807	7,459,218	45.96	57.41
	1	3,045	0	0	1	3,045	1	3,045	-	-
3月	8,235	75,116,577	8,096	74,691,496	139	425,081	23	71,250	1.69	0.57
	8,166	74,557,546	8,027	74,132,465	139	425,081	23	71,250	1.70	0.57
	69	559,031	69	559,031	0	0	0	0	0.00	0.00
計	85,528	748,726,651	13,951	107,771,705	71,577	640,954,946	43,759	204,221,174	83.69	85.61
	85,068	745,261,659	13,865	107,141,743	71,203	638,119,916	43,621	203,386,442	83.70	85.62
	460	3,464,992	86	629,962	374	2,835,030	138	834,732	81.30	81.82