

# 第3章. 上水道編

## 第5節 業務統計

# 1 配水分析

上段:上・簡水合算  
中段:上水道事業  
下段:簡易水道事業

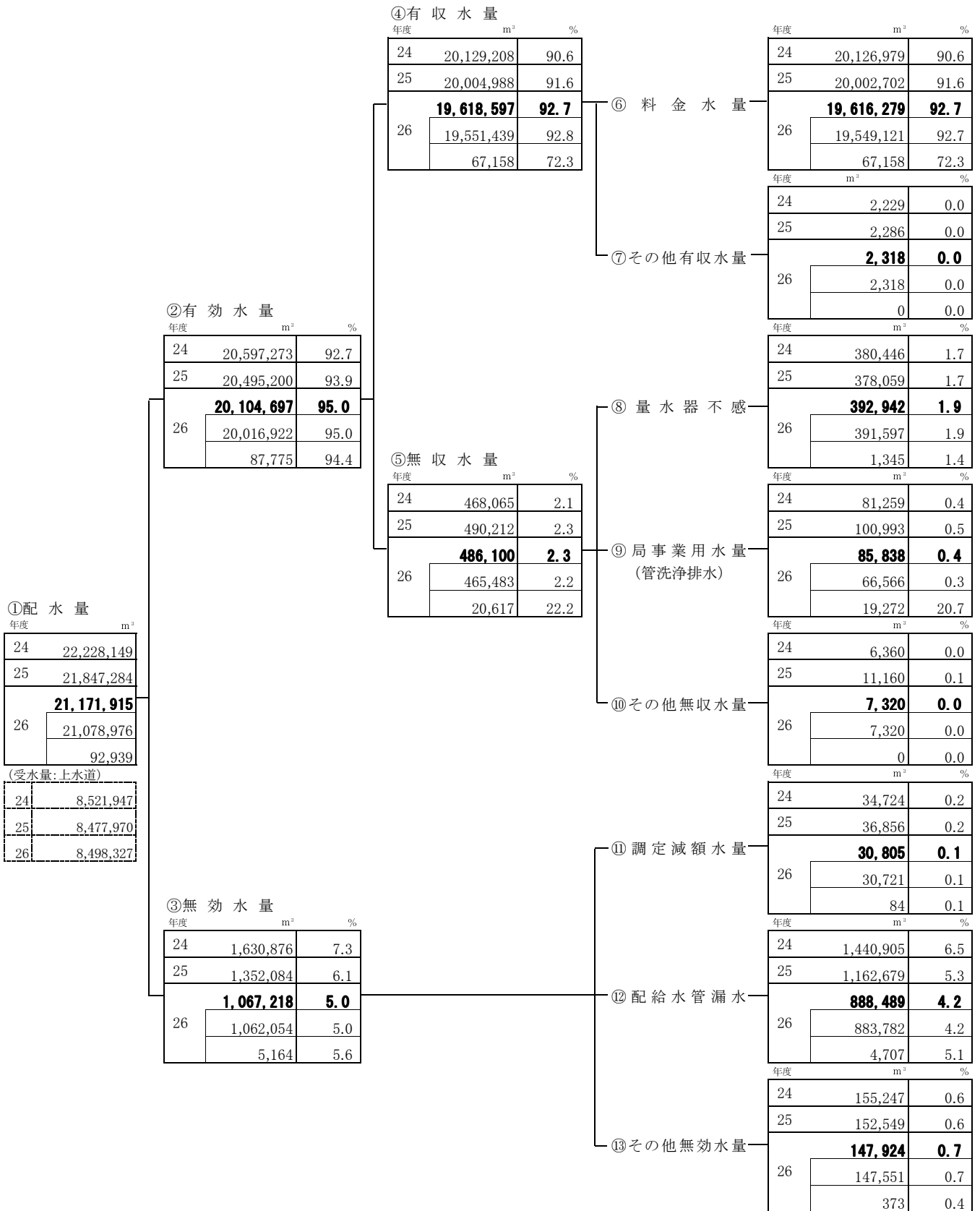

## 2 加入金の推移と変遷

### (1) 加入金の推移

上段：上・簡水合算

中段：上水道事業

下段：簡易水道事業

単位(件数):件

単位(金額):千円

口径 区分	年度		22		23		24		25		26	
	件数	構成比 (%)	件数	構成比 (%)	件数	構成比 (%)	件数	構成比 (%)	件数	構成比 (%)	件数	構成比 (%)
13mm	件数	567	57.9	360	37.7	555	41.7	599	45.2	621	41.3	
		523	56.4	354	37.3	552	41.6	599	45.2	617	41.2	
		44	84.6	6	75.0	3	50.0	0	0.0	4	80.0	
	金額	35,721	41.5	22,680	26.8	34,965	28.1	37,737	30.1	40,221	29.1	
		32,949	40.4	22,302	26.7	34,776	28.1	37,737	30.1	39,962	29.7	
		2,772	59.1	378	34.3	189	40.0	0	0.0	259	7.7	
20mm	件数	346	35.3	464	48.5	614	46.1	589	44.4	721	48.0	
		341	36.8	463	48.8	611	46.1	588	44.4	721	48.2	
		5	9.6	1	12.5	3	50.0	1	100.0	0	0.0	
	金額	32,697	38.0	43,848	51.7	58,024	46.7	55,661	44.3	70,081	50.8	
		32,225	39.6	43,753	52.3	57,740	46.7	55,566	44.3	70,081	52.0	
		473	10.1	95	8.6	284	60.0	95	100.0	0	0.0	
25mm	件数	15	1.5	18	1.9	11	0.8	31	2.3	27	1.8	
		14	1.5	18	1.9	11	0.8	31	2.3	27	1.8	
		1	1.9	0	0.0	0	0.0	0	0.0	0	0.0	
	金額	2,835	3.3	3,402	4.0	2,079	1.7	5,859	4.7	5,249	3.8	
		2,646	3.2	3,402	4.1	2,079	1.7	5,859	4.7	5,249	3.9	
		189	4.0	0	0.0	0	0.0	0	0.0	0	0.0	
40mm	件数	12	1.2	4	0.4	13	1.0	7	0.5	4	0.3	
		10	1.1	3	0.3	13	1.0	7	0.5	4	0.3	
		2	3.8	1	12.5	0	0.0	0	0.0	0	0.0	
	金額	7,560	8.8	2,520	3.0	8,190	6.6	4,410	3.5	2,592	1.9	
		6,300	7.7	1,890	2.3	8,190	6.6	4,410	3.5	2,592	1.9	
		1,260	26.8	630	57.1	0	0.0	0	0.0	0	0.0	
50mm	件数	0	0.0	0	0.0	2	0.2	5	0.4	1	0.1	
		0	0.0	0	0.0	2	0.2	5	0.4	1	0.1	
		0	0.0	0	0.0	0	0.0	0	0.0	0	0.0	
	金額	0	0.0	0	0.0	2,394	1.9	5,985	4.8	1,231	0.9	
		0	0.0	0	0.0	2,394	1.9	5,985	4.8	1,231	0.9	
		0	0.0	0	0.0	0	0.0	0	0.0	0	0.0	
75mm	件数	0	0.0	0	0.0	1	0.1	1	0.1	1	0.1	
		0	0.0	0	0.0	1	0.1	1	0.1	0	0.0	
		0	0.0	0	0.0	0	0.0	0	0.0	1	20.0	
	金額	0	0.0	0	0.0	3,024	2.4	3,024	2.4	3,110	2.3	
		0	0.0	0	0.0	3,024	2.4	3,024	2.4	0	0.0	
		0	0.0	0	0.0	0	0.0	0	0.0	3,110	92.3	
100mm	件数	0	0.0	0	0.0	0	0.0	0	0.0	0	0.0	
		0	0.0	0	0.0	0	0.0	0	0.0	0	0.0	
		0	0.0	0	0.0	0	0.0	0	0.0	0	0.0	
	金額	0	0.0	0	0.0	0	0.0	0	0.0	0	0.0	
		0	0.0	0	0.0	0	0.0	0	0.0	0	0.0	
		0	0.0	0	0.0	0	0.0	0	0.0	0	0.0	
小計	件数	940	96.0	846	88.5	1,196	89.8	1,232	92.9	1,375	91.5	
		888	95.8	838	88.4	1,190	89.7	1,231	92.9	1,370	91.5	
		52	100.0	8	100.0	6	100.0	1	100.0	5	100.0	
	金額	78,813	91.5	72,450	85.5	108,676	87.5	112,676	89.7	122,485	88.7	
		74,120	91.0	71,347	85.3	108,203	87.4	112,581	89.7	119,115	88.5	
		4,694	100.0	1,103	100.0	473	100.0	95	100.0	3,370	100.0	
口径 変更	件数	39	4.0	110	11.5	136	10.2	94	7.1	127	8.5	
		39	4.2	110	11.6	136	10.3	94	7.1	127	8.5	
		0	0.0	0	0.0	0	0.0	0	0.0	0	0.0	
	金額	7,340	8.5	12,285	14.5	15,561	12.5	12,883	10.3	15,552	11.3	
		7,340	9.0	12,285	14.7	15,561	12.6	12,883	10.3	15,552	11.5	
		0	0.0	0	0.0	0	0.0	0	0.0	0	0.0	
合計	件数	979	100.0	956	100.0	1,332	100.0	1,326	100.0	1,502	100.0	
		927	100.0	948	100.0	1,326	100.0	1,325	100.0	1,497	100.0	
		52	100.0	8	100.0	6	100.0	1	100.0	5	100.0	
	金額	86,153	100.0	84,735	100.0	124,237	100.0	125,559	100.0	138,037	100.0	
		81,459	100.0	83,632	100.0	123,764	100.0	125,464	100.0	134,667	100.0	
		4,694	100.0	1,103	100.0	473	100.0	95	100.0	3,370	100.0	

## (2) 加入金の変遷

### 【上水道事業】

#### 旧佐賀市

(単位 千円 消費税抜)

口径 改定日	13mm	20mm	25mm	40mm	50mm	75mm	100mm	150mm	200mm以上
昭和55. 4. 1	30	40	70	220	390	900	1,900	150mm 以上は管 理者が別 に定める	
59. 4. 1	40	60	120	400	800	2,000	3,800		
63. 4. 1	50	75	150	500	950	2,400	4,500		
平成 4.12. 1	60	90	180	600	1,140	2,880	5,400		
9.10. 1	60	90	180	600	1,140	2,880	5,400	10,800	管理者が別に定める

#### 旧大和町

(単位 千円 消費税抜)

口径 改定日	13mm	20mm	25mm	40mm	50mm	75mm	100mm	150mm
平成 4.4.1	120	168	287	777	1,360	3,059	5,437	町長が定める

#### 新佐賀市

(単位 千円 消費税抜)

口径 改定日	13mm	20mm	25mm	40mm	50mm	75mm	100mm	150mm	200mm以上
平成 18.4.1	60	90	180	600	1,140	2,880	5,400	10,800	管理者が別に定める

### 【簡易水道事業】

#### 大和簡易水道・大和飲料水供給施設

(単位 千円 消費税抜)

口径 改定日	13mm	20mm	25mm	40mm	50mm	75mm	100mm	150mm	200mm以上
平成 10.12.24	120	168	287	777	1,360	3,059	5,437	町長が定 める	-
平成 18.4.1	佐賀市水道事業の給水条例の規定の例による								

#### 富士南部簡易水道

(単位 千円 消費税抜)

口径 改定日	13mm	20mm	25mm	40mm	50mm	75mm	100mm	150mm	200mm以上
平成 16.4.1	120	168	-	-	-	-	-	-	-
平成 18.4.1	佐賀市水道事業の給水条例の規定の例による								

### 【上水道・簡易水道事業】

#### 現行

(単位 千円 消費税抜)

口径 改定日	13mm	20mm	25mm	40mm	50mm	75mm	100mm	150mm	200mm以上
平成 21.4.1	60	90	180	600	1,140	2,880	5,400	10,800	管理者が別に定める

### 3 用途別使用水量状況

(消費税含む)

用途 年度・期	一 般 用 用												湯 屋 用			福 祉 用			臨 時 用						
	上・簡水合算						上水道事業						簡易水道事業			件数	水量 m³	料金 円	件数	水量 m³	料金 円	件数	水量 m³	料金 円	
	件数	水量 m³	料金 円	件数	水量 m³	料金 円	件数	水量 m³	料金 円	件数	水量 m³	料金 円	件数	水量 m³	料金 円										件数
21	472,970	19,740,019	3,960,656,875	472,970	19,740,019	3,960,656,875	1,143	53,667	9,218,263	5	107	15,166	187	260,712	33,799,748	29	937	506,670							
22	475,759	19,745,901	3,957,680,002	475,759	19,745,901	3,957,680,002	1,161	56,349	9,664,002	1	2	283	217	276,126	35,958,154	32	1,109	599,677							
23	476,920	19,802,250	3,967,344,004	521,909	21,229,294	4,202,732,725	1,367	67,198	12,375,975	-	-	-	246	314,633	40,370,380	58	1,088	588,313							
24	523,276	21,296,492	4,215,108,700	485,426	19,396,253	3,823,107,135	1,432	63,678	12,375,523	-	-	-	173	267,984	35,237,658	41	890	481,792							
25	492,442	19,340,387	3,806,753,826	490,858	19,274,088	3,793,416,282	1,584	66,299	13,337,544	-	-	-	164	270,667	35,940,382	17	645	348,774							
26	497,154	18,999,433	3,823,775,691	495,462	18,932,275	3,809,664,206	1,692	67,158	14,111,485	-	-	-	164	267,397	36,564,440	23	578	321,476							
4月	38,443	1,350,864	267,760,482	38,443	1,350,864	267,760,482	-	-	-	-	-	-	7	12,589	1,751,351	-	-	-							
5月	44,013	1,698,556	333,002,452	43,740	1,687,936	330,860,838	273	10,620	2,141,614	-	-	-	20	30,394	3,987,515	-	-	-							
6月	38,356	1,411,097	282,979,191	38,355	1,411,097	282,977,949	1	-	1,242	-	-	-	7	12,863	1,834,685	1	30	16,686							
7月	44,162	1,810,440	367,034,276	43,883	1,799,140	364,684,709	279	11,300	2,349,567	-	-	-	20	32,590	4,376,671	1	2	1,112							
8月	38,356	1,431,345	287,668,291	38,355	1,431,317	287,663,842	1	28	4,449	-	-	-	7	12,821	1,830,375	1	1	556							
9月	44,331	1,830,177	371,510,535	44,048	1,818,710	369,138,352	283	11,467	2,372,183	-	-	-	20	33,154	4,495,432	1	5	2,781							
10月	38,414	1,389,498	279,339,778	38,414	1,389,498	279,339,778	-	-	-	-	-	-	7	13,113	1,862,980	2	5	2,780							
11月	44,313	1,766,839	356,273,829	44,026	1,755,510	353,849,504	287	11,329	2,424,325	-	-	-	20	31,874	4,314,765	4	446	248,064							
12月	38,407	1,412,867	285,435,849	38,407	1,412,867	285,435,849	-	-	-	-	-	-	7	12,268	1,745,584	7	24	13,346							
1月	44,375	1,753,825	352,521,049	44,091	1,742,453	350,105,248	284	11,372	2,415,801	-	-	-	20	31,437	4,241,240	-	-	-							
2月	38,527	1,461,173	298,995,487	38,527	1,461,173	298,995,487	-	-	-	-	-	-	7	12,135	1,723,120	4	47	26,140							
3月	45,457	1,682,752	341,254,472	45,173	1,671,710	338,852,168	284	11,042	2,402,304	-	-	-	22	32,159	4,400,722	2	18	10,011							
26年度構成比	100.0	96.9	98.0	99.6	96.5	97.7	0.3	0.3	0.4	0.0	0.0	0.0	0.0	1.4	0.9	0.0	0.0	0.0	0.0	0.0	0.0	0.0	0.0	0.0	
1件1か月の平均	-	19.1	3,846	-	19.1	3,845	-	19.9	4,170	-	-	-	-	815.2	111,477	-	12.6	6,989							

※簡易水道事業は一般用のみ

(消費税含む)

用途 年度・期	工 場 用						上・簡水合算						合 計						
	上水道事業合算			簡易水道事業合算			上水道事業合算			簡易水道事業合算			上水道事業合算			簡易水道事業合算			
	件数	水量 m <sup>3</sup>	料金 円	件数	水量 m <sup>3</sup>	料金 円	件数	水量 m <sup>3</sup>	料金 円	件数	水量 m <sup>3</sup>	料金 円	件数	水量 m <sup>3</sup>	料金 円	件数	水量 m <sup>3</sup>	料金 円	
21	30	298,741	33,423,731	474,364	20,354,183	4,037,620,453	473,221	20,300,516	4,028,402,190	1,143	53,667	9,218,263							
22	30	315,434	35,106,383	477,200	20,394,921	4,039,008,501	476,039	20,338,572	4,029,344,499	1,161	56,349	9,664,002							
23	35	418,733	45,745,197	477,200	20,394,921	4,039,008,501	476,039	20,338,572	4,029,344,499	1,367	67,198	12,375,975							
24	60	398,174	43,657,191	523,615	22,030,946	4,301,812,590	522,248	21,963,748	4,289,436,615	1,432	63,678	12,375,523							
25	65	391,003	44,018,152	492,688	20,002,702	3,887,061,134	491,104	19,936,403	3,873,723,590	1,584	66,299	13,337,544							
26	36	348,871	39,488,937	497,377	19,616,279	3,900,150,544	495,685	19,549,121	3,886,039,059	1,692	67,158	14,111,485							
4月	-	-	-	38,450	1,363,453	269,511,833	38,450	1,363,453	269,511,833	-	-	-							
5月	6	54,736	6,076,184	44,039	1,783,686	343,066,151	43,766	1,773,066	340,924,537	273	10,620	2,141,614							
6月	-	-	-	38,364	1,423,990	284,830,562	38,363	1,423,990	284,829,320	1	-	1,242							
7月	6	63,419	7,149,668	44,189	1,906,451	378,561,727	43,910	1,895,151	376,212,160	279	11,300	2,349,567							
8月	-	-	-	38,364	1,444,167	289,499,222	38,363	1,444,139	289,494,773	1	28	4,449							
9月	6	67,835	7,607,330	44,358	1,931,171	383,616,078	44,075	1,919,704	381,243,895	283	11,467	2,372,183							
10月	-	-	-	38,423	1,402,616	281,205,538	38,423	1,402,616	281,205,538	-	-	-							
11月	6	58,554	6,656,162	44,343	1,857,713	367,492,820	44,056	1,846,384	365,068,495	287	11,329	2,424,325							
12月	-	-	-	38,421	1,425,159	287,194,779	38,421	1,425,159	287,194,779	-	-	-							
1月	6	49,817	5,751,250	44,401	1,835,079	362,513,539	44,117	1,823,707	360,097,738	284	11,372	2,415,801							
2月	-	-	-	38,538	1,473,355	300,744,747	38,538	1,473,355	300,744,747	-	-	-							
3月	6	54,510	6,248,343	45,487	1,769,439	351,913,548	45,203	1,758,397	349,511,244	284	11,042	2,402,304							
26年度構成比	0.0	1.8	1.0	100.0	100.0	100.0	99.7	99.7	99.6	0.3	0.3	0.4							
1件1か月の平均	-	4,845	548,457	-	19.7	3,921	-	19.7	3,920	-	19.9	4,170							

※簡易水道事業は一般用のみ

#### 4 口径別使用水量状況

(単位 水量: m<sup>3</sup>、料金: 円・消費税含む)

	φ13mm	φ20mm	φ25mm	φ40mm	φ50mm	φ75mm	φ100mm	φ150mm	φ200mm	φ300mm	合計
上・簡水合算											
一般用											
件数	249,530	225,227	14,338	5,823	1,569	517	124	13	13	-	497,154
水量	6,584,476	7,050,240	1,138,895	2,184,920	1,034,727	640,022	289,117	49,430	27,606	-	18,999,433
料金	1,247,247,839	1,307,202,551	246,605,379	497,668,640	252,317,811	176,285,955	75,109,985	13,535,763	7,801,768	-	3,823,775,691
水道事業											
件数	248,114	225,005	14,326	5,799	1,557	511	124	13	13	-	495,462
水量	6,546,845	7,043,785	1,138,538	2,182,630	1,016,328	637,996	289,117	49,430	27,606	-	18,932,275
料金	1,240,538,415	1,306,128,088	246,538,912	497,217,790	247,048,855	175,744,630	75,109,985	13,535,763	7,801,768	-	3,809,664,206
簡易水道事業											
件数	1,416	222	12	24	12	6	-	-	-	-	1,692
水量	37,631	6,455	357	2,290	18,399	2,026	-	-	-	-	67,158
料金	6,709,424	1,074,463	66,467	450,850	5,268,956	541,325	-	-	-	-	14,111,485
湯屋用											
件数	-	-	-	-	-	-	-	-	-	-	-
水量	-	-	-	-	-	-	-	-	-	-	-
料金	-	-	-	-	-	-	-	-	-	-	-
臨時用											
件数	18	3	1	-	-	1	-	-	-	-	23
水量	98	53	7	-	-	420	-	-	-	-	578
料金	54,501	29,478	3,893	-	-	233,604	-	-	-	-	321,476
福祉用											
件数	-	-	6	103	49	6	-	-	-	-	164
水量	-	-	12	142,859	93,713	30,813	-	-	-	-	267,397
料金	-	-	1,223	19,725,032	12,978,859	3,859,326	-	-	-	-	36,564,440
工場用											
件数	-	-	-	12	-	18	6	-	-	-	36
水量	-	-	-	-	-	307,851	31,459	-	-	-	348,871
料金	-	-	-	2,070,963	-	33,572,798	3,845,176	-	-	-	39,488,937
上・簡水合算											
件数	249,548	225,230	14,345	5,938	1,618	542	130	13	13	-	497,377
水量	6,584,574	7,050,293	1,138,914	2,337,340	1,128,440	979,106	320,576	49,430	27,606	-	19,616,279
料金	1,247,302,340	1,307,232,029	246,610,495	519,464,635	265,296,670	213,951,683	78,955,161	13,535,763	7,801,768	-	3,900,150,544
水道事業											
件数	248,132	225,008	14,333	5,914	1,606	536	130	13	13	-	495,685
水量	6,546,943	7,043,838	1,138,557	2,335,050	1,110,041	977,080	320,576	49,430	27,606	-	19,549,121
料金	1,240,592,916	1,306,157,566	246,544,028	519,013,785	260,027,714	213,410,358	78,955,161	13,535,763	7,801,768	-	3,886,039,059
簡易水道事業											
件数	1,416	222	12	24	12	6	-	-	-	-	1,692
水量	37,631	6,455	357	2,290	18,399	2,026	-	-	-	-	67,158
料金	6,709,424	1,074,463	66,467	450,850	5,268,956	541,325	-	-	-	-	14,111,485
合計											
件数	249,548	225,230	14,345	5,938	1,618	542	130	13	13	-	497,377
水量	6,584,574	7,050,293	1,138,914	2,337,340	1,128,440	979,106	320,576	49,430	27,606	-	19,616,279
料金	1,247,302,340	1,307,232,029	246,610,495	519,464,635	265,296,670	213,951,683	78,955,161	13,535,763	7,801,768	-	3,900,150,544
水道事業											
件数	248,132	225,008	14,333	5,914	1,606	536	130	13	13	-	495,685
水量	6,546,943	7,043,838	1,138,557	2,335,050	1,110,041	977,080	320,576	49,430	27,606	-	19,549,121
料金	1,240,592,916	1,306,157,566	246,544,028	519,013,785	260,027,714	213,410,358	78,955,161	13,535,763	7,801,768	-	3,886,039,059
簡易水道事業											
件数	1,416	222	12	24	12	6	-	-	-	-	1,692
水量	37,631	6,455	357	2,290	18,399	2,026	-	-	-	-	67,158
料金	6,709,424	1,074,463	66,467	450,850	5,268,956	541,325	-	-	-	-	14,111,485

## 5 検針業務状況

上段：上・簡水合算

中段：上水道事業

下段：簡易水道事業

(単位:件)

区分 月別	人員 (人)	検針件数	1人1ヶ月 平均件数	1人1ヶ月		検針不能
				最高	最低	
26年4月	<b>14</b>	<b>40,693</b>	<b>2,907</b>	<b>4,052</b>	<b>855</b>	<b>8</b>
	14	40,693	2,907	4,052	855	8
	-	-	-	-	-	-
5月	<b>16</b>	<b>47,119</b>	<b>2,945</b>	<b>4,359</b>	<b>1,813</b>	<b>5</b>
	13	46,813	3,601	4,359	1,813	5
	3	306	102	-	-	0
6月	<b>14</b>	<b>40,722</b>	<b>2,909</b>	<b>4,051</b>	<b>813</b>	<b>10</b>
	14	40,722	2,909	4,051	813	10
	-	-	-	-	-	-
7月	<b>16</b>	<b>47,196</b>	<b>2,950</b>	<b>4,375</b>	<b>1,819</b>	<b>2</b>
	13	46,885	3,607	4,375	1,819	2
	3	311	104	-	-	0
8月	<b>15</b>	<b>40,743</b>	<b>2,716</b>	<b>4,045</b>	<b>847</b>	<b>15</b>
	15	40,743	2,716	4,045	847	15
	-	-	-	-	-	-
9月	<b>16</b>	<b>47,272</b>	<b>2,955</b>	<b>4,391</b>	<b>1,816</b>	<b>4</b>
	13	46,961	3,612	4,391	1,816	4
	3	311	104	-	-	0
10月	<b>14</b>	<b>40,865</b>	<b>2,919</b>	<b>4,044</b>	<b>856</b>	<b>4</b>
	14	40,865	2,919	4,044	856	4
	-	-	-	-	-	-
11月	<b>16</b>	<b>47,438</b>	<b>2,965</b>	<b>4,400</b>	<b>1,825</b>	<b>1</b>
	13	47,126	3,625	4,400	1,825	1
	3	312	104	-	-	0
12月	<b>14</b>	<b>40,897</b>	<b>2,921</b>	<b>4,061</b>	<b>852</b>	<b>6</b>
	14	40,897	2,921	4,061	852	6
	-	-	-	-	-	-
27年1月	<b>17</b>	<b>50,329</b>	<b>2,961</b>	<b>4,651</b>	<b>1,898</b>	<b>1</b>
	14	49,981	3,570	4,651	1,898	1
	3	348	116	-	-	0
2月	<b>15</b>	<b>43,776</b>	<b>2,918</b>	<b>4,339</b>	<b>854</b>	<b>3</b>
	15	43,776	2,918	4,339	854	3
	-	-	-	-	-	-
3月	<b>17</b>	<b>47,665</b>	<b>2,804</b>	<b>4,446</b>	<b>1,840</b>	<b>0</b>
	14	47,350	3,382	4,446	1,840	0
	3	315	105	-	-	0
合計	-	<b>534,715</b>	-	-	-	<b>59</b>
	-	532,812	-	-	-	59
	-	1,903	-	-	-	0
平均	<b>15</b>	<b>44,560</b>	<b>2,906</b>	<b>4,268</b>	<b>1,341</b>	<b>5</b>
	14	44,401	3,210	4,268	1,341	5
	3	317	106	-	-	0



## 6 水道料金調定及び収入状況

上段：上・簡水合算

中段：上水道事業

下段：簡易水道事業

【全体】

項目 月別	調定		未納分		収納		収納率	
	件数(件)	金額(円)	件数(件)	金額(円)	件数(件)	金額(円)	件数(%)	金額(%)
26年4月	<b>38,450</b>	<b>269,511,833</b>	<b>78</b>	<b>283,073</b>	<b>38,376</b>	<b>269,228,760</b>	<b>99.81</b>	<b>99.89</b>
	38,450	269,511,833	78	283,073	38,376	269,228,760	99.81	99.89
	0	0	0	0	0	0	-	-
5月	<b>44,039</b>	<b>343,066,151</b>	<b>89</b>	<b>315,258</b>	<b>43,952</b>	<b>342,750,893</b>	<b>99.80</b>	<b>99.91</b>
	43,766	340,924,537	89	315,258	43,679	340,609,279	99.80	99.91
	273	2,141,614	0	0	273	2,141,614	100.00	100.00
6月	<b>38,364</b>	<b>284,830,562</b>	<b>88</b>	<b>324,312</b>	<b>38,276</b>	<b>284,506,250</b>	<b>99.77</b>	<b>99.89</b>
	38,363	284,829,320	88	324,312	38,275	284,505,008	99.77	99.89
	1	1,242	0	0	1	1,242	100.00	100.00
7月	<b>44,189</b>	<b>378,561,727</b>	<b>98</b>	<b>408,377</b>	<b>44,091</b>	<b>378,153,350</b>	<b>99.78</b>	<b>99.89</b>
	43,910	376,212,160	98	408,377	43,812	375,803,783	99.78	99.89
	279	2,349,567	0	0	279	2,349,567	100.00	100.00
8月	<b>38,364</b>	<b>289,499,222</b>	<b>82</b>	<b>266,676</b>	<b>38,282</b>	<b>289,232,546</b>	<b>99.79</b>	<b>99.91</b>
	38,363	289,494,773	82	266,676	38,281	289,228,097	99.79	99.91
	1	4,449	0	0	1	4,449	100.00	100.00
9月	<b>44,358</b>	<b>383,616,078</b>	<b>100</b>	<b>524,532</b>	<b>44,260</b>	<b>383,091,546</b>	<b>99.78</b>	<b>99.86</b>
	44,075	381,243,895	100	524,532	43,977	380,719,363	99.78	99.86
	283	2,372,183	0	0	283	2,372,183	100.00	100.00
10月	<b>38,423</b>	<b>281,205,538</b>	<b>160</b>	<b>907,478</b>	<b>38,263</b>	<b>280,298,060</b>	<b>99.58</b>	<b>99.68</b>
	38,423	281,205,538	160	907,478	38,263	280,298,060	99.58	99.68
	0	0	0	0	0	0	-	-
11月	<b>44,343</b>	<b>367,492,820</b>	<b>144</b>	<b>701,836</b>	<b>44,199</b>	<b>366,790,984</b>	<b>99.68</b>	<b>99.81</b>
	44,056	365,068,495	144	701,836	43,912	364,366,659	99.67	99.81
	287	2,424,325	0	0	287	2,424,325	100.00	100.00
12月	<b>38,421</b>	<b>287,194,779</b>	<b>552</b>	<b>3,289,221</b>	<b>37,869</b>	<b>283,905,558</b>	<b>98.56</b>	<b>98.85</b>
	38,421	287,194,779	552	3,289,221	37,869	283,905,558	98.56	98.85
	0	0	0	0	0	0	-	-
27年1月	<b>44,401</b>	<b>362,513,539</b>	<b>1,863</b>	<b>10,726,315</b>	<b>42,540</b>	<b>351,787,224</b>	<b>95.81</b>	<b>97.04</b>
	44,117	360,097,738	1,848	10,649,377	42,271	349,448,361	95.82	97.04
	284	2,415,801	15	76,938	269	2,338,863	94.72	96.82
2月	<b>38,538</b>	<b>300,744,747</b>	<b>7,800</b>	<b>63,878,216</b>	<b>30,738</b>	<b>236,866,531</b>	<b>79.76</b>	<b>78.76</b>
	38,538	300,744,747	7,800	63,878,216	30,738	236,866,531	79.76	78.76
	0	0	0	0	0	0	-	-
3月	<b>45,487</b>	<b>351,913,548</b>	<b>45,313</b>	<b>351,283,810</b>	<b>174</b>	<b>629,738</b>	<b>0.38</b>	<b>0.18</b>
	45,203	349,511,244	45,029	348,881,506	174	629,738	0.38	0.18
	284	2,402,304	284	2,402,304	0	0	0.00	0.00
計	<b>497,377</b>	<b>3,900,150,544</b>	<b>56,367</b>	<b>432,909,104</b>	<b>441,020</b>	<b>3,467,241,440</b>	<b>88.67</b>	<b>88.90</b>
	495,685	3,886,039,059	56,068	430,429,862	439,627	3,455,609,197	88.69	88.92
	1,692	14,111,485	299	2,479,242	1,393	11,632,243	82.33	82.43

上段：上・簡水合算  
 中段：上水道事業  
 下段：簡易水道事業

【口座制】

項目 月別	調 定		未 納 分		収 納		収 納 率	
	件数(件)	金額(円)	件数(件)	金額(円)	件数(件)	金額(円)	件数(%)	金額(%)
26年4月	<b>32,069</b>	<b>223,010,984</b>	<b>21</b>	<b>83,925</b>	<b>32,051</b>	<b>222,927,059</b>	<b>99.94</b>	<b>99.96</b>
	32,069	223,010,984	21	83,925	32,051	222,927,059	99.94	99.96
	0	0	0	0	0	0	-	-
5月	<b>36,589</b>	<b>275,504,501</b>	<b>19</b>	<b>68,265</b>	<b>36,572</b>	<b>275,436,236</b>	<b>99.95</b>	<b>99.98</b>
	36,387	273,730,975	19	68,265	36,370	273,662,710	99.95	99.98
	202	1,773,526	0	0	202	1,773,526	100.00	100.00
6月	<b>32,149</b>	<b>231,051,804</b>	<b>23</b>	<b>78,680</b>	<b>32,127</b>	<b>230,973,124</b>	<b>99.93</b>	<b>99.97</b>
	32,149	231,051,804	23	78,680	32,127	230,973,124	99.93	99.97
	0	0	0	0	0	0	-	-
7月	<b>36,670</b>	<b>297,705,324</b>	<b>23</b>	<b>116,117</b>	<b>36,647</b>	<b>297,589,207</b>	<b>99.94</b>	<b>99.96</b>
	36,466	295,763,708	23	116,117	36,443	295,647,591	99.94	99.96
	204	1,941,616	0	0	204	1,941,616	100.00	100.00
8月	<b>32,129</b>	<b>235,002,075</b>	<b>25</b>	<b>70,769</b>	<b>32,104</b>	<b>234,931,306</b>	<b>99.92</b>	<b>99.97</b>
	32,129	235,002,075	25	70,769	32,104	234,931,306	99.92	99.97
	0	0	0	0	0	0	-	-
9月	<b>36,770</b>	<b>301,597,808</b>	<b>22</b>	<b>173,911</b>	<b>36,749</b>	<b>301,423,897</b>	<b>99.94</b>	<b>99.94</b>
	36,561	299,649,486	22	173,911	36,540	299,475,575	99.94	99.94
	209	1,948,322	0	0	209	1,948,322	100.00	100.00
10月	<b>32,127</b>	<b>231,318,454</b>	<b>73</b>	<b>565,527</b>	<b>32,054</b>	<b>230,752,927</b>	<b>99.77</b>	<b>99.76</b>
	32,127	231,318,454	73	565,527	32,054	230,752,927	99.77	99.76
	0	0	0	0	0	0	-	-
11月	<b>36,760</b>	<b>292,205,132</b>	<b>25</b>	<b>139,226</b>	<b>36,735</b>	<b>292,065,906</b>	<b>99.93</b>	<b>99.95</b>
	36,546	290,339,855	25	139,226	36,521	290,200,629	99.93	99.95
	214	1,865,277	0	0	214	1,865,277	100.00	100.00
12月	<b>32,144</b>	<b>237,340,861</b>	<b>227</b>	<b>1,655,416</b>	<b>31,918</b>	<b>235,685,445</b>	<b>99.30</b>	<b>99.30</b>
	32,144	237,340,861	227	1,655,416	31,918	235,685,445	99.30	99.30
	0	0	0	0	0	0	-	-
27年1月	<b>36,748</b>	<b>291,342,919</b>	<b>512</b>	<b>3,343,162</b>	<b>36,237</b>	<b>287,999,757</b>	<b>98.61</b>	<b>98.85</b>
	36,537	289,457,230	508	3,324,122	36,030	286,133,108	98.61	98.85
	211	1,885,689	4	19,040	207	1,866,649	98.10	98.99
2月	<b>32,237</b>	<b>251,235,908</b>	<b>4,586</b>	<b>42,756,546</b>	<b>27,652</b>	<b>208,479,362</b>	<b>85.78</b>	<b>82.98</b>
	32,237	251,235,908	4,586	42,756,546	27,652	208,479,362	85.78	82.98
	0	0	0	0	0	0	-	-
3月	<b>37,467</b>	<b>277,293,288</b>	<b>37,439</b>	<b>277,212,162</b>	<b>28</b>	<b>81,126</b>	<b>0.07</b>	<b>0.03</b>
	37,256	275,448,916	37,228	275,367,790	28	81,126	0.08	0.03
	211	1,844,372	211	1,844,372	0	0	0.00	0.00
計	<b>413,859</b>	<b>3,144,609,058</b>	<b>42,995</b>	<b>326,263,706</b>	<b>370,874</b>	<b>2,818,345,352</b>	<b>89.61</b>	<b>89.62</b>
	412,608	3,133,350,256	42,780	324,400,294	369,838	2,808,949,962	89.63	89.65
	1,251	11,258,802	215	1,863,412	1,036	9,395,390	82.81	83.45

【納付制】

項目 月別	調定		未納分		収納		コンビニ収納		収納率	
	件数(件)	金額(円)	件数(件)	金額(円)	件数(件)	金額(円)	件数(件)	金額(円)	件数(%)	金額(%)
26年4月	<b>6,381</b>	<b>46,500,849</b>	<b>57</b>	<b>199,148</b>	<b>6,325</b>	<b>46,301,701</b>	<b>3,479</b>	<b>14,502,810</b>	<b>99.12</b>	<b>99.57</b>
	6,381	46,500,849	57	199,148	6,325	46,301,701	3,479	14,502,810	99.12	99.57
	0	0	0	0	0	0	0	0	-	-
5月	<b>7,450</b>	<b>67,561,650</b>	<b>70</b>	<b>246,993</b>	<b>7,380</b>	<b>67,314,657</b>	<b>4,307</b>	<b>20,064,081</b>	<b>99.06</b>	<b>99.63</b>
	7,379	67,193,562	70	246,993	7,309	66,946,569	4,281	19,917,587	99.05	99.63
	71	368,088	0	0	71	368,088	26	146,494	100.00	100.00
6月	<b>6,215</b>	<b>53,778,758</b>	<b>65</b>	<b>245,632</b>	<b>6,149</b>	<b>53,533,126</b>	<b>3,305</b>	<b>15,134,083</b>	<b>98.94</b>	<b>99.54</b>
	6,214	53,777,516	65	245,632	6,148	53,531,884	3,304	15,132,841	98.94	99.54
	1	1,242	0	0	1	1,242	1	1,242	100.00	100.00
7月	<b>7,519</b>	<b>80,856,403</b>	<b>75</b>	<b>292,260</b>	<b>7,444</b>	<b>80,564,143</b>	<b>4,301</b>	<b>20,882,807</b>	<b>99.00</b>	<b>99.64</b>
	7,444	80,448,452	75	292,260	7,369	80,156,192	4,275	20,723,639	98.99	99.64
	75	407,951	0	0	75	407,951	26	159,168	100.00	100.00
8月	<b>6,235</b>	<b>54,497,147</b>	<b>57</b>	<b>195,907</b>	<b>6,178</b>	<b>54,301,240</b>	<b>3,341</b>	<b>15,524,855</b>	<b>99.09</b>	<b>99.64</b>
	6,234	54,492,698	57	195,907	6,177	54,296,791	3,341	15,524,855	99.09	99.64
	1	4,449	0	0	1	4,449	0	0	-	-
9月	<b>7,588</b>	<b>82,018,270</b>	<b>78</b>	<b>350,621</b>	<b>7,511</b>	<b>81,667,649</b>	<b>4,331</b>	<b>21,784,945</b>	<b>98.99</b>	<b>99.57</b>
	7,514	81,594,409	78	350,621	7,437	81,243,788	4,303	21,631,252	98.98	99.57
	74	423,861	0	0	74	423,861	28	153,693	100.00	100.00
10月	<b>6,296</b>	<b>49,887,084</b>	<b>87</b>	<b>341,951</b>	<b>6,209</b>	<b>49,545,133</b>	<b>3,466</b>	<b>16,399,366</b>	<b>98.62</b>	<b>99.31</b>
	6,296	49,887,084	87	341,951	6,209	49,545,133	3,466	16,399,366	98.62	99.31
	0	0	0	0	0	0	0	0	-	-
11月	<b>7,583</b>	<b>75,287,688</b>	<b>119</b>	<b>562,610</b>	<b>7,464</b>	<b>74,725,078</b>	<b>4,499</b>	<b>21,878,547</b>	<b>98.43</b>	<b>99.25</b>
	7,510	74,728,640	119	562,610	7,391	74,166,030	4,475	21,731,465	98.42	99.25
	73	559,048	0	0	73	559,048	24	147,082	100.00	100.00
12月	<b>6,277</b>	<b>49,853,918</b>	<b>325</b>	<b>1,633,805</b>	<b>5,951</b>	<b>48,220,113</b>	<b>3,454</b>	<b>16,344,569</b>	<b>94.81</b>	<b>96.72</b>
	6,277	49,853,918	325	1,633,805	5,951	48,220,113	3,454	16,344,569	94.81	96.72
	0	0	0	0	0	0	0	0	-	-
27年1月	<b>7,653</b>	<b>71,170,620</b>	<b>1,351</b>	<b>7,383,153</b>	<b>6,303</b>	<b>63,787,467</b>	<b>4,506</b>	<b>21,505,431</b>	<b>82.36</b>	<b>89.63</b>
	7,580	70,640,508	1,340	7,325,255	6,241	63,315,253	4,478	21,340,206	82.34	89.63
	73	530,112	11	57,898	62	472,214	28	165,225	84.93	89.08
2月	<b>6,301</b>	<b>49,508,839</b>	<b>3,214</b>	<b>21,121,670</b>	<b>3,086</b>	<b>28,387,169</b>	<b>1,885</b>	<b>8,079,125</b>	<b>48.98</b>	<b>57.34</b>
	6,301	49,508,839	3,214	21,121,670	3,086	28,387,169	1,885	8,079,125	48.98	57.34
	0	0	0	0	0	0	0	0	-	-
3月	<b>8,020</b>	<b>74,620,260</b>	<b>7,874</b>	<b>74,071,648</b>	<b>146</b>	<b>548,612</b>	<b>39</b>	<b>92,014</b>	<b>1.82</b>	<b>0.74</b>
	7,947	74,062,328	7,801	73,513,716	146	548,612	39	92,014	1.84	0.74
	73	557,932	73	557,932	0	0	0	0	0.00	0.00
計	<b>83,518</b>	<b>755,541,486</b>	<b>13,372</b>	<b>106,645,398</b>	<b>70,146</b>	<b>648,896,088</b>	<b>40,913</b>	<b>192,192,633</b>	<b>83.99</b>	<b>85.88</b>
	83,077	752,688,803	13,288	106,029,568	69,789	646,659,235	40,780	191,419,729	84.01	85.91
	441	2,852,683	84	615,830	357	2,236,853	133	772,904	80.95	78.41