

第3章. 上水道編

第5節 業務統計

1 配水分析

上段:上・簡水合算
中段:上水道事業
下段:簡易水道事業

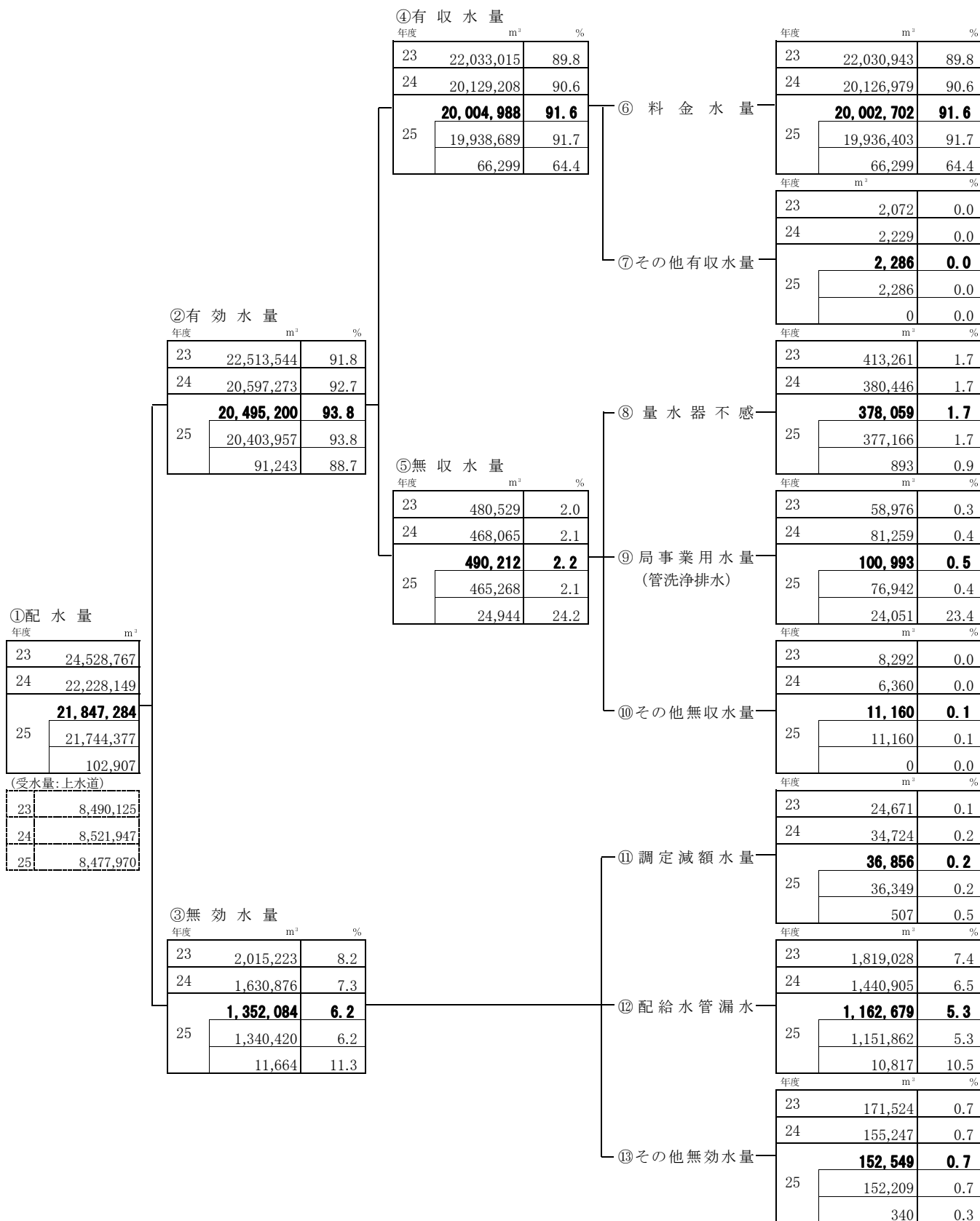

2 加入金の推移と変遷

(1) 加入金の推移

上段：上・簡水合算

中段：上水道事業

下段：簡易水道事業

単位(件数):件

単位(金額):千円

口径 区分	年度	21		22		23		24		25	
		件数	構成比 (%)	件数	構成比 (%)	件数	構成比 (%)	件数	構成比 (%)	件数	構成比 (%)
13mm	件数	516	48.0	567	57.9	360	37.7	555	41.7	599	45.2
		511	47.8	523	56.4	354	37.3	552	41.6	599	45.2
		5	83.3	44	84.6	6	75.0	3	50.0	0	0.0
	金額	32,508	36.3	35,721	41.5	22,680	26.8	34,965	28.1	37,737	30.1
		32,193	36.1	32,949	40.4	22,302	26.7	34,776	28.1	37,737	30.1
		315	76.9	2,772	59.1	378	34.3	189	40.0	0	0.0
20mm	件数	501	46.6	346	35.3	464	48.5	614	46.1	589	44.4
		500	46.7	341	36.8	463	48.8	611	46.1	588	44.4
		1	16.7	5	9.6	1	12.5	3	50.0	1	100.0
	金額	47,345	52.8	32,697	38.0	43,848	51.7	58,024	46.7	55,661	44.3
		47,250	53.0	32,225	39.6	43,753	52.3	57,740	46.7	55,566	44.3
		95	23.1	473	10.1	95	8.6	284	60.0	95	100.0
25mm	件数	12	1.1	15	1.5	18	1.9	11	0.8	31	2.3
		12	1.1	14	1.5	18	1.9	11	0.8	31	2.3
		0	0.0	1	1.9	0	0.0	0	0.0	0	0.0
	金額	2,268	2.5	2,835	3.3	3,402	4.0	2,079	1.7	5,859	4.7
		2,268	2.5	2,646	3.2	3,402	4.1	2,079	1.7	5,859	4.7
		0	0.0	189	4.0	0	0.0	0	0.0	0	0.0
40mm	件数	2	0.2	12	1.2	4	0.4	13	1.0	7	0.5
		2	0.2	10	1.1	3	0.3	13	1.0	7	0.5
		0	0.0	2	3.8	1	12.5	0	0.0	0	0.0
	金額	1,260	1.4	7,560	8.8	2,520	3.0	8,190	6.6	4,410	3.5
		1,260	1.4	6,300	7.7	1,890	2.3	8,190	6.6	4,410	3.5
		0	0.0	1,260	26.8	630	57.1	0	0.0	0	0.0
50mm	件数	1	0.1	0	0.0	0	0.0	2	0.2	5	0.4
		1	0.1	0	0.0	0	0.0	2	0.2	5	0.4
		0	0.0	0	0.0	0	0.0	0	0.0	0	0.0
	金額	1,197	1.3	0	0.0	0	0.0	2,394	1.9	5,985	4.8
		1,197	1.3	0	0.0	0	0.0	2,394	1.9	5,985	4.8
		0	0.0	0	0.0	0	0.0	0	0.0	0	0.0
75mm	件数	0	0.0	0	0.0	0	0.0	1	0.1	1	0.1
		0	0.0	0	0.0	0	0.0	1	0.1	1	0.1
		0	0.0	0	0.0	0	0.0	0	0.0	0	0.0
	金額	0	0.0	0	0.0	0	0.0	3,024	2.4	3,024	2.4
		0	0.0	0	0.0	0	0.0	3,024	2.4	3,024	2.4
		0	0.0	0	0.0	0	0.0	0	0.0	0	0.0
100mm	件数	0	0.0	0	0.0	0	0.0	0	0.0	0	0.0
		0	0.0	0	0.0	0	0.0	0	0.0	0	0.0
		0	0.0	0	0.0	0	0.0	0	0.0	0	0.0
	金額	0	0.0	0	0.0	0	0.0	0	0.0	0	0.0
		0	0.0	0	0.0	0	0.0	0	0.0	0	0.0
		0	0.0	0	0.0	0	0.0	0	0.0	0	0.0
小計	件数	1,032	95.9	940	96.0	846	88.5	1,196	89.8	1,232	92.9
		1,026	95.9	888	95.8	838	88.4	1,190	89.7	1,231	92.9
		6	100.0	52	100.0	8	100.0	6	100.0	1	100.0
	金額	84,578	94.4	78,813	91.5	72,450	85.5	108,676	87.5	112,676	89.7
		84,168	94.4	74,120	91.0	71,347	85.3	108,203	87.4	112,581	89.7
		410	100.0	4,694	100.0	1,103	100.0	473	100.0	95	100.0
口径 変更	件数	44	4.1	39	4.0	110	11.5	136	10.2	94	7.1
		44	4.1	39	4.2	110	11.6	136	10.3	94	7.1
		0	0.0	0	0.0	0	0.0	0	0.0	0	0.0
	金額	5,009	5.6	7,340	8.5	12,285	14.5	15,561	12.5	12,883	10.3
		5,009	5.6	7,340	9.0	12,285	14.7	15,561	12.6	12,883	10.3
		0	0.0	0	0.0	0	0.0	0	0.0	0	0.0
合計	件数	1,076	100.0	979	100.0	956	100.0	1,332	100.0	1,326	100.0
		1,070	100.0	927	100.0	948	100.0	1,326	100.0	1,325	100.0
		6	100.0	52	100.0	8	100.0	6	100.0	1	100.0
	金額	89,586	100.0	86,153	100.0	84,735	100.0	124,237	100.0	125,559	100.0
		89,177	100.0	81,459	100.0	83,632	100.0	123,764	100.0	125,464	100.0
		410	100.0	4,694	100.0	1,103	100.0	473	100.0	95	100.0

(2) 加入金の変遷

【上水道事業】

旧佐賀市

(単位 千円 消費税抜)

口径 改定日	13mm	20mm	25mm	40mm	50mm	75mm	100mm	150mm	200mm以上
昭和55. 4. 1	30	40	70	220	390	900	1,900	150mm 以上は管 理者が別 に定める	
59. 4. 1	40	60	120	400	800	2,000	3,800		
63. 4. 1	50	75	150	500	950	2,400	4,500		
平成 4.12. 1	60	90	180	600	1,140	2,880	5,400		
9.10. 1	60	90	180	600	1,140	2,880	5,400	10,800	管理者が別に定める

旧大和町

(単位 千円 消費税抜)

口径 改定日	13mm	20mm	25mm	40mm	50mm	75mm	100mm	150mm
平成 4.4.1	120	168	287	777	1,360	3,059	5,437	町長が定める

新佐賀市

(単位 千円 消費税抜)

口径 改定日	13mm	20mm	25mm	40mm	50mm	75mm	100mm	150mm	200mm以上
平成 18.4.1	60	90	180	600	1,140	2,880	5,400	10,800	管理者が別に定める

【簡易水道事業】

大和簡易水道・大和飲料水供給施設

(単位 千円 消費税抜)

口径 改定日	13mm	20mm	25mm	40mm	50mm	75mm	100mm	150mm	200mm以上
平成 10.12.24	120	168	287	777	1,360	3,059	5,437	町長が定 める	-
平成 18.4.1	佐賀市水道事業の給水条例の規定の例による								

富士南部簡易水道

(単位 千円 消費税抜)

口径 改定日	13mm	20mm	25mm	40mm	50mm	75mm	100mm	150mm	200mm以上
平成 16.4.1	120	168	-	-	-	-	-	-	-
平成 18.4.1	佐賀市水道事業の給水条例の規定の例による								

【上水道・簡易水道事業】

現行

(単位 千円 消費税抜)

口径 改定日	13mm	20mm	25mm	40mm	50mm	75mm	100mm	150mm	200mm以上
平成 21.4.1	60	90	180	600	1,140	2,880	5,400	10,800	管理者が別に定める

3 用途別使用水量状況

(消費税含む)

用途 年度・期	一 般 用 用												湯 屋 用			福 祉 用			臨 時 用					
	上・簡水合算						上水道事業						簡易水道事業			件数	水量 m ³	料 金 円	件数	水量 m ³	料 金 円	件数	水量 m ³	料 金 円
	件数	水量 m ³	料 金 円	件数	水量 m ³	料 金 円	件数	水量 m ³	料 金 円	件数	水量 m ³	料 金 円	件数	水量 m ³	料 金 円									
20	471,722	19,880,956	3,999,913,292	471,722	19,880,956	3,999,913,292	-	-	-	-	-	12	1,003	142,171	177	255,336	32,851,852	71	1,642	887,882				
21	472,970	19,740,019	3,960,656,875	472,970	19,740,019	3,960,656,875	1,143	53,667	9,218,263	1,143	53,667	5	107	15,166	187	260,712	33,799,748	29	937	506,670				
22	475,759	19,745,901	3,957,680,002	475,759	19,745,901	3,957,680,002	1,161	56,349	9,664,002	1,161	56,349	1	2	283	217	276,126	35,958,154	32	1,109	599,677				
23	476,920	19,802,250	3,967,344,004	521,909	21,229,294	4,202,732,725	1,367	67,198	12,375,975	1,367	67,198	-	-	-	246	314,633	40,370,380	58	1,088	588,313				
24	523,276	21,296,492	4,215,108,700	485,426	19,396,253	3,823,107,135	1,432	63,678	12,375,523	1,432	63,678	-	-	-	173	267,984	35,237,658	41	890	481,792				
25	492,442	19,340,387	3,806,753,826	490,858	19,274,088	3,793,416,282	1,584	66,299	13,337,544	1,584	66,299	608	36,318	8,595,417	286	273,017	36,390,823	479	21,675	3,008,711				
4月	38,137	1,388,736	276,448,872	38,136	1,388,688	276,440,556	1	48	8,316	1	48	-	-	-	7	11,774	1,636,318	4	13	7,028				
5月	43,495	1,753,576	344,465,488	43,234	1,742,777	342,337,180	261	10,799	2,128,308	261	10,799	100	5,964	1,420,114	40	32,018	4,211,125	79	3,493	387,106				
6月	38,109	1,434,171	279,125,264	38,108	1,434,171	279,124,057	1	-	1,207	1	-	-	-	-	7	12,885	1,795,839	1	1	540				
7月	43,612	1,822,601	359,158,118	43,349	1,811,640	356,960,820	263	10,961	2,197,298	263	10,961	100	6,163	1,452,342	41	33,888	4,508,303	78	3,414	416,461				
8月	38,156	1,489,890	291,682,982	38,155	1,489,890	291,681,775	1	-	1,207	1	-	-	-	-	7	13,990	1,940,608	2	3	2,829				
9月	43,843	1,890,163	374,235,250	43,580	1,878,258	371,880,007	263	11,905	2,355,243	263	11,905	102	6,532	1,537,432	40	33,578	4,387,541	78	3,718	446,265				
10月	38,245	1,435,343	280,138,268	38,244	1,435,342	280,137,061	1	1	1,207	1	1	1	1	1,207	7	13,560	1,883,383	2	3	1,621				
11月	43,776	1,773,460	348,514,379	43,512	1,762,456	346,335,236	264	11,004	2,179,143	264	11,004	101	5,919	1,399,758	40	31,926	4,157,968	79	4,010	670,938				
12月	38,121	1,428,261	280,184,515	38,121	1,428,261	280,184,515	-	-	-	-	-	-	-	-	7	13,039	1,817,947	-	-	-				
1月	43,744	1,751,560	343,016,995	43,482	1,740,776	340,864,067	262	10,784	2,152,928	262	10,784	101	5,922	1,401,608	41	31,604	4,127,125	76	3,371	408,135				
2月	38,278	1,483,438	296,583,691	38,278	1,483,438	296,583,691	-	-	-	-	-	-	-	-	7	12,781	1,773,191	3	174	94,089				
3月	44,926	1,689,188	333,200,004	44,659	1,678,391	330,887,317	267	10,797	2,312,687	267	10,797	103	5,817	1,382,956	42	31,974	4,151,475	77	3,475	573,699				
25年度構成比	100.0	96.7	97.9	99.6	96.4	97.6	0.3	0.3	0.3	0.3	0.3	0.1	0.2	0.2	0.1	1.4	0.9	0.1	0.1	0.1	0.1			
1件1か月の平均	-	19.6	3,865	-	19.6	3,864	-	20.9	4,210	-	20.9	-	-	-	-	477.3	63,620	-	22.6	-	3,141			

※簡易水道事業は一般用のみ

(消費税含む)

用途 年度・期	工 場 用						上・簡水合算						合 計					
	上水道事業合算			簡易水道事業合算			上水道事業合算			簡易水道事業合算			上水道事業合算			簡易水道事業合算		
	件数 件	水量 m ³	料 金 円	件数 件	水量 m ³	料 金 円	件数 件	水量 m ³	料 金 円	件数 件	水量 m ³	料 金 円	件数 件	水量 m ³	料 金 円	件数 件	水量 m ³	料 金 円
20	35	293,830	32,951,242	472,017	20,432,767	4,066,746,439	472,017	20,432,767	4,066,746,439	-	-	-	-	-	-	-	-	-
21	30	298,741	33,423,731	474,364	20,354,183	4,037,620,453	473,221	20,300,516	4,028,402,190	1,143	53,667	9,218,263	1,143	53,667	9,218,263	1,143	53,667	9,218,263
22	30	315,434	35,106,383	477,200	20,394,921	4,039,008,501	476,039	20,338,572	4,029,344,499	1,161	56,349	9,664,002	1,161	56,349	9,664,002	1,161	56,349	9,664,002
23	35	418,733	45,745,197	477,200	20,394,921	4,039,008,501	476,039	20,338,572	4,029,344,499	1,367	67,198	12,375,975	1,367	67,198	12,375,975	1,367	67,198	12,375,975
24	60	398,174	43,657,191	523,615	22,030,946	4,301,812,590	522,248	21,963,748	4,289,436,615	1,432	63,678	12,375,523	1,432	63,678	12,375,523	1,432	63,678	12,375,523
25	457	397,604	45,649,901	492,688	20,002,702	3,887,061,134	491,104	19,936,403	3,873,723,590	1,584	66,299	13,337,544	1,584	66,299	13,337,544	1,584	66,299	13,337,544
4月	6	1,724	453,988	38,153	1,402,199	278,537,890	38,152	1,402,151	278,529,574	1	48	8,316	1	48	8,316	1	48	8,316
5月	69	61,843	6,870,414	43,522	1,846,095	355,225,939	43,261	1,835,296	353,097,631	261	10,799	2,128,308	261	10,799	2,128,308	261	10,799	2,128,308
6月	6	1,163	303,711	38,122	1,448,220	281,224,147	38,121	1,448,220	281,222,940	1	-	1,207	1	-	1,207	1	-	1,207
7月	71	72,050	7,962,961	43,639	1,927,155	371,300,887	43,376	1,916,194	369,103,589	263	10,961	2,197,298	263	10,961	2,197,298	263	10,961	2,197,298
8月	5	1,229	318,716	38,169	1,505,112	293,943,928	38,168	1,505,112	293,942,721	1	-	1,207	1	-	1,207	1	-	1,207
9月	70	77,163	8,497,478	43,870	1,999,249	386,748,723	43,607	1,987,344	384,393,480	263	11,905	2,355,243	263	11,905	2,355,243	263	11,905	2,355,243
10月	5	2,301	616,086	38,259	1,451,207	282,639,358	38,258	1,451,206	282,638,151	1	1	1,207	1	1	1,207	1	1	1,207
11月	72	68,447	7,612,700	43,804	1,872,758	360,176,600	43,540	1,861,754	357,997,457	264	11,004	2,179,143	264	11,004	2,179,143	264	11,004	2,179,143
12月	5	709	172,126	38,133	1,442,009	282,174,588	38,133	1,442,009	282,174,588	-	-	-	-	-	-	-	-	-
1月	70	59,888	6,770,730	43,770	1,841,561	353,571,665	43,508	1,830,777	351,418,737	262	10,784	2,152,928	262	10,784	2,152,928	262	10,784	2,152,928
2月	5	1,105	282,271	38,293	1,497,498	298,733,242	38,293	1,497,498	298,733,242	-	-	-	-	-	-	-	-	-
3月	73	49,982	5,788,720	44,954	1,769,639	342,784,167	44,687	1,758,842	340,471,480	267	10,797	2,312,687	267	10,797	2,312,687	267	10,797	2,312,687
25年度構成比	0.1	2.0	1.2	100.0	100.0	100.0	99.7	99.7	99.7	0.3	0.3	0.3	0.3	0.3	0.3	0.3	0.3	0.3
1件1か月の平均	-	435	49,945	-	20.3	3,945	-	20.3	3,944	-	20.9	4,210	-	20.9	4,210	-	20.9	4,210

※簡易水道事業は一般用のみ

4 口径別使用水量状況

(単位 水量:m³、料金:円・消費税含む)

	φ13mm	φ20mm	φ25mm	φ40mm	φ50mm	φ75mm	φ100mm	φ150mm	φ200mm	φ300mm	合計
上・簡水合算											
件数	248,289	222,088	14,120	5,756	1,541	505	118	12	13	-	492,442
水量	6,714,545	7,125,794	1,179,113	2,216,471	1,040,690	665,788	304,577	46,943	46,466	-	19,340,387
料金	1,240,185,335	1,290,660,662	250,831,547	493,763,170	250,636,459	179,391,930	76,787,040	12,379,100	12,118,583	-	3,806,753,826
一般用											
水道事業	246,964	221,877	14,108	5,732	1,529	505	118	12	13	-	491,800
水量	6,676,267	7,119,237	1,178,826	2,214,209	1,021,775	665,788	304,577	46,943	46,466	-	19,335,578
料金	1,233,665,468	1,289,624,459	250,777,537	493,324,208	245,347,957	179,391,930	76,787,040	12,379,100	12,118,583	-	3,805,808,277
簡易水道事業	1,325	211	12	24	12	-	-	-	-	-	1,584
水量	38,278	6,557	287	2,262	18,915	-	-	-	-	-	66,299
料金	6,519,867	1,036,203	54,010	438,962	5,288,502	-	-	-	-	-	13,337,544
湯屋用											
件数	-	-	-	-	-	-	-	-	-	-	-
水量	-	-	-	-	-	-	-	-	-	-	-
料金	-	-	-	-	-	-	-	-	-	-	-
臨時用											
件数	11	3	1	-	1	1	-	-	-	-	17
水量	23	4	9	-	172	437	-	-	-	-	645
料金	12,431	2,161	4,866	-	93,009	236,307	-	-	-	-	348,774
福祉用											
件数	-	-	6	103	49	6	-	-	-	-	164
水量	-	-	38	147,440	90,640	32,549	-	-	-	-	270,667
料金	-	-	3,788	19,908,625	12,371,105	3,656,864	-	-	-	-	35,940,382
工場用											
件数	-	18	-	17	-	18	12	-	-	-	65
水量	-	439	-	9,124	-	344,669	36,771	-	-	-	391,003
料金	-	86,349	-	1,973,042	-	36,494,657	5,464,104	-	-	-	44,018,152
上・簡水合算											
件数	248,300	222,109	14,127	5,876	1,591	530	130	12	13	-	492,688
水量	6,714,568	7,126,237	1,179,160	2,373,035	1,131,502	1,043,443	341,348	46,943	46,466	-	20,002,702
料金	1,240,197,766	1,290,749,172	250,840,201	515,644,837	263,100,573	219,779,758	82,251,144	12,379,100	12,118,583	-	3,887,061,134
合計											
水道事業合算											
件数	246,975	221,898	14,115	5,852	1,579	530	130	12	13	-	491,104
水量	6,676,290	7,119,680	1,178,873	2,370,773	1,112,587	1,043,443	341,348	46,943	46,466	-	19,936,403
料金	1,233,677,899	1,289,712,969	250,786,191	515,205,875	257,812,071	219,779,758	82,251,144	12,379,100	12,118,583	-	3,873,723,590
簡易水道事業合算											
件数	1,325	211	12	24	12	-	-	-	-	-	1,584
水量	38,278	6,557	287	2,262	18,915	-	-	-	-	-	66,299
料金	6,519,867	1,036,203	54,010	438,962	5,288,502	-	-	-	-	-	13,337,544

5 検針業務状況

上段：上・簡水合算

中段：上水道事業

下段：簡易水道事業

(単位:件)

区分 月別	人 員 (人)	検針件数	1人1ヶ月 平均件数	1人1ヶ月		検針不能
				最 高	最 低	
25年4月	14	40,535	2,895	4,025	875	6
	14	40,535	2,895	4,025	875	6
	-	-	-	-	-	-
5月	16	46,451	3,647	4,228	1,786	1
	13	46,164	3,551	4,228	1,786	1
	3	287	96	-	-	-
6月	14	40,527	2,895	4,028	869	9
	14	40,527	2,895	4,028	869	9
	-	-	-	-	-	-
7月	16	46,530	3,653	4,232	1,791	5
	13	46,242	3,557	4,232	1,791	5
	3	288	96	-	-	-
8月	15	40,531	2,702	4,035	188	5
	15	40,531	2,702	4,035	188	5
	-	-	-	-	-	-
9月	16	46,695	2,613	4,249	1,784	3
	13	46,407	2,517	4,249	1,784	3
	3	288	96	-	-	-
10月	14	40,587	2,899	4,050	871	5
	14	40,587	2,899	4,050	871	5
	-	-	-	-	-	-
11月	16	46,827	3,676	4,228	1,789	3
	13	46,539	3,580	4,228	1,789	3
	3	288	96	-	-	-
12月	14	40,542	2,896	4,058	870	5
	14	40,542	2,896	4,058	874	5
	-	-	-	-	-	-
26年1月	16	49,649	3,902	4,514	1,858	4
	13	49,325	3,794	4,514	1,858	4
	3	324	108	-	-	-
2月	14	43,407	3,101	4,329	864	11
	14	43,407	3,101	4,329	877	11
	-	-	-	-	-	-
3月	16	46,978	3,688	4,357	1,798	2
	13	46,687	3,591	4,357	1,798	2
	3	291	97	-	-	-
合 計	-	529,259	-	-	-	59
	-	527,493	-	-	-	59
	-	1,766	-	-	-	-
平 均	15	44,105	3,214	4,194	1,279	5
	14	43,958	3,165	4,194	1,280	5
	3	294	108	-	-	-

6 水道料金調定及び収入状況

上段：上・簡水合算
中段：上水道事業
下段：簡易水道事業

【全体】

項目 月別	調定		未納分		収納		収納率	
	件数(件)	金額(円)	件数(件)	金額(円)	件数(件)	金額(円)	件数(%)	金額(%)
25年4月	38,153	278,537,890	80	381,375	38,076	278,156,515	99.80	99.86
	38,152	278,529,574	80	381,375	38,075	278,148,199	99.80	99.86
	1	8,316	0	0	1	8,316	-	-
5月	43,522	355,225,939	78	300,253	43,446	354,925,686	99.83	99.92
	43,261	353,097,631	78	300,253	43,185	352,797,378	99.82	99.91
	261	2,128,308	0	0	261	2,128,308	-	-
6月	38,122	281,224,147	78	376,850	38,045	280,847,297	99.80	99.87
	38,121	281,222,940	78	376,850	38,044	280,846,090	99.80	99.87
	1	1,207	0	0	1	1,207	-	-
7月	43,639	371,300,887	112	511,836	43,529	370,789,051	99.75	99.86
	43,376	369,103,589	112	511,836	43,266	368,591,753	99.75	99.86
	263	2,197,298	0	0	263	2,197,298	-	-
8月	38,169	293,943,928	95	466,671	38,074	293,477,257	99.75	99.84
	38,168	293,942,721	95	466,671	38,073	293,476,050	99.75	99.84
	1	1,207	0	0	1	1,207	-	-
9月	43,870	386,748,723	121	457,653	43,751	386,291,070	99.73	99.88
	43,607	384,393,480	120	454,923	43,489	383,938,557	99.73	99.88
	263	2,355,243	1	2,730	262	2,352,513	-	-
10月	38,259	282,639,358	143	728,974	38,117	281,910,384	99.63	99.74
	38,258	282,638,151	143	728,974	38,116	281,909,177	99.63	99.74
	1	1,207	0	0	1	1,207	-	-
11月	43,804	360,176,600	152	779,884	43,654	359,396,716	99.66	99.78
	43,540	357,997,457	151	777,154	43,391	357,220,303	99.66	99.78
	264	2,179,143	1	2,730	263	2,176,413	-	-
12月	38,133	282,174,588	506	3,224,424	37,627	278,950,164	98.67	98.86
	38,133	282,174,588	506	3,224,424	37,627	278,950,164	98.67	98.86
	0	0	0	0	0	0	-	-
26年1月	43,770	353,571,665	2,067	11,565,817	41,704	342,005,848	95.28	96.73
	43,508	351,418,737	2,055	11,503,522	41,454	339,915,215	95.28	96.73
	262	2,152,928	12	62,295	250	2,090,633	-	-
2月	38,293	298,733,242	4,221	23,421,759	34,072	275,311,483	88.98	92.16
	38,293	298,733,242	4,221	23,421,759	34,072	275,311,483	88.98	92.16
	0	0	0	0	0	0	-	-
3月	44,954	342,784,167	44,786	342,265,973	168	518,194	0.37	0.15
	44,687	340,471,480	44,519	339,953,286	168	518,194	0.38	0.15
	267	2,312,687	267	2,312,687	0	0	-	-
計	492,688	3,887,061,134	52,439	384,481,469	440,263	3,502,579,665	89.36	90.11
	491,104	3,873,723,590	52,158	382,101,027	438,960	3,491,622,563	89.38	90.14
	1,584	13,337,544	281	2,380,442	1,303	10,957,102	82.26	82.15

上段：上・簡水合算
 中段：上水道事業
 下段：簡易水道事業

【口座制】

項目 月別	調定		未納分		収納		収納率	
	件数(件)	金額(円)	件数(件)	金額(円)	件数(件)	金額(円)	件数(%)	金額(%)
25年4月	32,142	234,307,883	26	78,305	32,117	234,229,578	99.92	99.97
	32,141	234,299,567	26	78,305	32,116	234,221,262	99.92	99.97
	1	8,316	0	0	1	8,316	100.00	100.00
5月	36,275	285,247,085	17	74,542	36,259	285,172,543	99.96	99.97
	36,082	283,473,577	17	74,542	36,066	283,399,035	99.96	99.97
	193	1,773,508	0	0	193	1,773,508	100.00	100.00
6月	32,241	228,970,874	74	60,521	32,228	228,910,353	99.96	99.97
	32,241	228,970,874	74	60,521	32,228	228,910,353	99.96	99.97
	0	0	0	0	0	0	-	-
7月	36,338	290,259,220	26	138,309	36,313	290,120,911	99.93	99.95
	36,142	288,428,929	26	138,309	36,117	288,290,620	99.93	99.95
	196	1,830,291	0	0	196	1,830,291	100.00	100.00
8月	32,237	236,268,663	24	91,541	32,213	236,177,122	99.93	99.96
	32,236	236,267,456	24	91,541	32,212	236,175,915	99.93	99.96
	1	1,207	0	0	1	1,207	100.00	100.00
9月	36,383	302,152,859	27	90,198	36,357	302,062,661	99.93	99.97
	36,188	300,193,658	27	90,198	36,162	300,103,460	99.93	99.97
	195	1,959,201	0	0	195	1,959,201	100.00	100.00
10月	32,208	233,283,748	18	79,214	32,190	233,204,534	99.94	99.97
	32,208	233,283,748	18	79,214	32,190	233,204,534	99.94	99.97
	0	0	0	0	0	0	-	-
11月	36,357	285,924,385	25	146,369	36,334	285,778,016	99.94	99.95
	36,159	284,130,340	25	146,369	36,136	283,983,971	99.94	99.95
	198	1,794,045	0	0	198	1,794,045	100.00	100.00
12月	32,139	232,880,867	115	840,126	32,024	232,040,741	99.64	99.64
	32,139	232,880,867	115	840,126	32,024	232,040,741	99.64	99.64
	0	0	0	0	0	0	-	-
26年1月	36,360	283,190,146	642	4,400,526	35,719	278,789,620	98.24	98.45
	36,165	281,405,967	641	4,393,607	35,525	277,012,360	98.23	98.44
	195	1,784,179	1	6,919	194	1,777,260	99.49	99.61
2月	32,239	251,020,534	1,465	9,152,332	30,774	241,868,202	95.46	96.35
	32,239	251,020,534	1,465	9,152,332	30,774	241,868,202	95.46	96.35
	0	0	0	0	0	0	-	-
3月	37,181	273,492,080	37,162	273,425,765	24	66,315	0.06	0.02
	36,980	271,716,977	36,961	271,650,662	24	66,315	0.06	0.02
	201	1,775,103	201	1,775,103	0	0	0.00	0.00
計	412,100	3,136,998,344	39,621	288,577,748	372,552	2,848,420,596	90.40	90.80
	410,920	3,126,072,494	39,419	286,795,726	371,574	2,839,276,768	90.42	90.83
	1,180	10,925,850	202	1,782,022	978	9,143,828	82.88	83.69

【納付制】

項目 月別	調定		未納分		収納		コンビニ収納		収納率	
	件数(件)	金額(円)	件数(件)	金額(円)	件数(件)	金額(円)	件数(件)	金額(円)	件数(%)	金額(%)
25年4月	6,011	44,230,007	54	303,070	5,959	43,926,937	3,154	13,536,615	99.13	99.31
	6,011	44,230,007	54	303,070	5,959	43,926,937	3,154	13,536,615	99.13	99.31
	0	0	0	0	0	0	0	0	-	-
5月	7,247	69,978,854	61	225,711	7,187	69,753,143	3,987	17,958,586	99.17	99.68
	7,179	69,624,054	61	225,711	7,119	69,398,343	3,965	17,834,180	99.16	99.68
	68	354,800	0	0	68	354,800	22	124,406	100.00	100.00
6月	5,881	52,253,273	4	316,329	5,817	51,936,944	3,044	14,504,934	98.91	99.39
	5,880	52,252,066	4	316,329	5,816	51,935,737	3,043	14,503,727	98.91	99.39
	1	1,207	0	0	1	1,207	1	1,207	100.00	100.00
7月	7,301	81,041,667	86	373,527	7,216	80,668,140	3,993	18,808,340	98.84	99.54
	7,234	80,674,660	86	373,527	7,149	80,301,133	3,971	18,670,083	98.82	99.54
	67	367,007	0	0	67	367,007	22	138,257	100.00	100.00
8月	5,932	57,675,265	71	375,130	5,861	57,300,135	3,128	15,380,512	98.80	99.35
	5,932	57,675,265	71	375,130	5,861	57,300,135	3,128	15,380,512	98.80	99.35
	0	0	0	0	0	0	0	0	-	-
9月	7,487	84,595,864	94	367,455	7,394	84,228,409	4,022	19,322,741	98.76	99.57
	7,419	84,199,822	93	364,725	7,327	83,835,097	4,003	19,189,655	98.76	99.57
	68	396,042	1	2,730	67	393,312	19	133,086	98.53	99.31
10月	6,051	49,355,610	125	649,760	5,927	48,705,850	3,307	15,195,473	97.95	98.68
	6,050	49,354,403	125	649,760	5,926	48,704,643	3,306	15,194,266	97.95	98.68
	1	1,207	0	0	1	1,207	1	1,207	100.00	100.00
11月	7,447	74,252,215	127	633,515	7,320	73,618,700	4,226	19,749,923	98.29	99.15
	7,381	73,867,117	126	630,785	7,255	73,236,332	4,205	19,615,314	98.29	99.15
	66	385,098	1	2,730	65	382,368	21	134,609	98.48	99.29
12月	5,994	49,293,721	391	2,384,298	5,603	46,909,423	3,193	14,871,234	93.48	95.16
	5,994	49,293,721	391	2,384,298	5,603	46,909,423	3,193	14,871,234	93.48	95.16
	0	0	0	0	0	0	0	0	-	-
26年1月	7,410	70,381,519	1,425	7,165,291	5,985	63,216,228	3,953	18,991,938	80.77	89.82
	7,343	70,012,770	1,414	7,109,915	5,929	62,902,855	3,936	18,875,636	80.74	89.84
	67	368,749	11	55,376	56	313,373	17	116,302	83.58	84.98
2月	6,054	47,712,708	2,756	14,269,427	3,298	33,443,281	1,493	5,942,012	54.48	70.09
	6,054	47,712,708	2,756	14,269,427	3,298	33,443,281	1,493	5,942,012	54.48	70.09
	0	0	0	0	0	0	0	0	-	-
3月	7,773	69,292,087	7,624	68,840,208	144	451,879	26	59,899	1.85	0.65
	7,707	68,754,503	7,558	68,302,624	144	451,879	26	59,899	1.87	0.66
	66	537,584	66	537,584	0	0	0	0	0.00	0.00
計	80,588	750,062,790	12,818	95,903,721	67,711	654,159,069	37,526	174,322,207	84.02	87.21
	80,184	747,651,096	12,739	95,305,301	67,386	652,345,795	37,423	173,673,133	84.04	87.25
	404	2,411,694	79	598,420	325	1,813,274	103	649,074	80.45	75.19